

Stock code : 3322



JOINSOON ELECTRONICS MFG. CO., LTD.

Year 2025 Annual Report

Annual Report is available at: <http://mops.twse.com.tw>
<http://www.jem.com.tw>

The website designated by the Financial Supervisory Commission for information reporting: Same as above

Printed on May 19, 2026

1.Spokesperson for the Company

Spokesperson : Huang, Chin-Chi

Title : General Manager

Tel : (02) 2698-4882

E-mail : jem.ir@jem.com.tw

Deputy Spokesperson : Ou, Keng-Hung

Title : Vice President

Tel : (02) 2698-4882

E-mail : jem.ir@jem.com.tw

2.Company, plant address and telephone number

Address : 19F., No. 79, Sec. 1, Xintai 5th Rd., Xizhi Dist., New Taipei City 221006 ,
Taiwan, R.O.C.

Tel : (02) 2698-4882

3.Name, address, website and telephone number of the stock transfer office

Name : Stock Agency Department of KGI Securities Co., Ltd.

Address : 5F., No. 2, Sec. 1, Chongqing S. Rd., Zhongzheng Dist., Taipei City
100502 , Taiwan, R.O.C.

Website : [http : //www.kgieworld.com.tw](http://www.kgieworld.com.tw)

Tel : (02) 2389-2999

4.CPA for the most recent annual financial report

Accountant's Name : Ou, Yao-Chun.Wang, I-Wen

Accounting Firm : KPMG

Address : 68F., No. 7, Sec. 5, Xinyi Rd., Xinyi Dist., Taipei City 110615, Taiwan,
R.O.C.

Website : [http : //www.kpmg.com.tw](http://www.kpmg.com.tw)

Tel : (02) 8101-6666

5.Name of the exchange where the overseas marketable securities are listed and how to inquire the information of the overseas marketable securities: None**6.Corporate Website : [http : //www.jem.com.tw](http://www.jem.com.tw)**

Table of Contents

	Page
I.Letter to Shareholders.....	1
II.Corporate Governance Report.....	5
1.Directors, Supervisors, General Manager, Deputy General Manager, Associates, Departments and Branches Officer Information	5
2.Remuneration paid to directors, supervisors, general manager and deputy general manager for the most recent year	12
3.Corporate Governance Status	19
4.Information on CPA Professional Fees	43
5. The Company has changed its accountant information in the recent two years and subsequent periods	43
6. Independent Evaluation of Accountants	43
7.Chairman, General Manager, or Any Managerial Officer in Charge of Financial or Accounting Matters in the Most Recent Fiscal Year Holding a Position at the CPAs' Accounting Firm or at an Affiliate of Such Accounting Firm	44
8.Changes in the shareholding of directors, managers and shareholders holding more than 10% of the shares as well as changes in shareholding pledges for the most recent year ended on the date of publication of the annual report	44
9.Information on the top ten shareholders who are related to each other or are spouses or second-degree relatives	45
10.Total Numbers and Equity of Shares Held In any Single Enterprise by the Company, Directors, Supervisors, Managers and Any Companies Controlled Either Directly or Indirectly by the Company	46
III.Information on Capital Raising Activities.....	47
1.Capital and Shares	47
2.Issuance of Corporate Bonds	49
3.Issuance of Preferred stock	51
4. Issuance of Depository Receipt	51
5.Employee Stock Options	51
6.Issuance of Restricted Stock for Employees---	51
7.Issuance of New Shares for Merger, Acquisition or Exchange of Other Companies' Shares	51
8.Financing Plans and Implementation	51
IV.Operations Profile.....	52
1.Business Scope	52
2.Market and Sales Overview	66
3.Employee information	80
4.Environmental Expenditure Information	80
5.Labor Relations	81
6.Cyber security management	85
7.Important Contracts	85

V. Financial Status and Financial Performance Review Analysis and Risk	
Issues.....	86
1. Financial Status	86
2. Financial Performance	87
3. Cash flow	88
4. Effect Upon Financial Operations of Any Major Capital Expenditures during the Most Recent Fiscal Year	88
5. Investment Policy for the Most Recent Fiscal Year, Main Reasons for Profits/Losses Generated Thereby, Plan for Improving Investment Profitability, and Investment Plans for the Coming Year	89
6. Risk analysis and evaluation	89
7. Other Important Matters	93
VI. Special Disclosure.....	94
1. Information on affiliated companies	94
2. Private Placement of Securities during the Most Recent Fiscal Year or during the Current Fiscal Year up to the Date of Publication of the Annual Report	98
3. Holding or Disposal of Shares in the Company by Subsidiaries during the Most Recent Fiscal Year or during the Current Fiscal Year up to the Date of Publication of the Annual Report	98
4. Other Supplementary Information	98
VII. Matters of Significant Effects on Shareholders' Interests or Securities Price Stipulated in Subparagraph 2, Paragraph 3, and Article 36 of the Securities and Exchange Act.....	98

I. Letter to Shareholders

Ladies and gentlemen of the shareholders:

Looking back at the past year, global economic growth in 2025 remained steady at approximately 3.2%, compared with the previous year. In the first half of the year, markets fell into a slump due to the Trump administration's tariff policies and geopolitical uncertainties; however, the subsequent "front-loading" effect by businesses and the gradual clarification of policies boosted export momentum in the second half of the year, while gradually stabilizing inflation and easing labor market pressures supported the economic fundamentals. In addition, demand for AI-related semiconductors and servers has grown far beyond expectations, becoming a key pillar supporting global trade. It is expected that by 2026, the global market will have gradually adapted to the new normal of "high tariffs and high volatility," with companies shifting toward more resilient local supply chain. Meanwhile, AI technology is evolving from early-stage hardware deployment toward software applications and industrial empowerment, which will become a key driver of future productivity growth and help offset some of the negative impacts of geopolitical tensions.

The results of our 2025 business and a summary of our 2026 business plan are as follows:

1. 2025 Business Results

(1) Business Plan Implement Results

The Company's 2025 Consolidated Operating Revenue was NT\$ 3,004,391 thousand, an growth of 6% compared to 2024, Consolidated Gross Profit was NT\$ 413,308 thousand, a decrease of 1% compared to 2024, Consolidated Operating Net loss was NT\$ 106,644 thousand and after-tax loss per share was NT\$ 0.96 in 2025.

Category	2025	2024	Unit: NT\$ thousand	
			+/-	%
Consolidated Operating Revenue	3,004,391	2,826,393	177,998	6%
Consolidated Operating Costs	2,591,083	2,409,412	181,671	8%
Consolidated Gross Profit	413,308	416,981	(3,673)	-1%
Consolidated Operating Expenses	519,952	571,881	(51,929)	-9%
Consolidated Operating Income (loss)	(106,644)	(154,900)	48,256	-31%
Consolidated Non-operating Income	(17,915)	69,068	(86,983)	-126%
Consolidated Pre-Tax Income (loss)	(124,559)	(85,832)	(38,727)	45%
Consolidated Profit (loss), attributable to owners of parent	(116,729)	(101,133)	(15,596)	15%

(2) Estimated implementation of the situation

The Company is not required to disclose financial projections in 2025, so there is no budget achievement.

(3) Financial Structure, solvency and profitability analysis

Category		2025	2024	
Financial Structure	Debt Ratio (%)	54.65	51.64	
	Current Ratio (%)	115.53	150.80	
Profitability	Return on Assets (%)	-2.65	-2.35	
	Return on Equity (%)	-7.31	-6.11	
	Ratio to Capital Stock (%)	Operation Income	-8.77	-12.74
		Profit Before Tax	-10.24	-7.06
	Net Profit Margin (%)	-3.89	-3.33	
Earnings Per Share (NT\$)	-0.96	-0.87		

Note: Including non-controlling interests.

(4) Research and Development Status

Unit: NT\$ thousand

Category / Year	2025	2024
Consolidated Research & Development Expense	160,130	208,213
Consolidated Net Revenue	3,004,391	2,826,393
Ratio of Consolidated R&D Expense to Net Revenue	5.33%	7.37%

The technologies or products developed in 2025 are as follows:

1. Thunderbolt5 Passive cable, Coaxial, 0.8~1.5m
2. Thunderbolt5 Passive cable, Twisted Pair, 0.3~0.8m
3. Thunderbolt5 Active Cable. Coaxial, 2.0m
4. USB 4 TO PCI-e M.2 SSD..
5. Wi-Fi extend
6. NAS for Media

2. 2026 Business Plan Summary

(1) Management Policy

1. Deeply rooted in corporate values, train key technical talent, laying the foundation for the long-term development of the company.
2. continue to develop our core technology of high frequency cables and connectors to strengthen our core competitive advantage.
3. Maintain a solid financial structure and optimize cash flow control to meet long-term development needs.
4. Continuously promote and implement ESG sustainable development strategy, and enhance the Company's investment in environment, society and corporate governance.

(2) Expected sales volume and its basis

Based on the Company's operating results in 2025, evaluation of recent orders and industry information, our colleagues will continue to expand our business and develop new products.

(3) Important Production and Marketing Policies

1. Continue to promote Toyoda-style management and automation to improve productivity and management capabilities.
2. Optimize the strategic division of labor and resource allocation among overseas factories (Thailand, China), strengthen localized supply and global inventory management capabilities, and enhance cost competitiveness.
3. We are actively developing international customers to diversify the risk of operation concentration.
4. We are actively expanding into other non-consumer electronic components industries, such as medical devices and industrial controls, to mitigate the risk of volatility in single market.

3. Future development strategy of the company

- (1) Actively increase the proportion of high-margin products, optimize the product portfolio, and focus on dual growth in revenue scale and profitability to maximize return on shareholders' equity.
- (2) Based on the connection component technology, we continue to develop high frequency technology products, and expand the non-consumer electronic components industry.
- (3) Continuously shifting the production and engineering focus, leveraging regional production advantages to provide the most competitive pricing and services. By vertically integrating R&D (NPI) with production, we accelerate the transferring from R&D to mass production and ensure growth momentum in revenue and profitability.

4. Influenced by the external competitive environment, regulatory environment and general business environment

- (1) Global economic growth in 2025 is approximately 3.2%. Although the economy has been impacted by the new U.S. administration's shift in trade policy and geopolitical volatility, it has demonstrated resilience, driven by the benefits of investment in artificial intelligence (AI) infrastructure. Looking ahead to 2026, the global economy is expected to enter a new normal as "low growth and high-tech drivers," with the International Monetary Fund (IMF) projecting that the growth rate will remain around 3.1%. Although inflation has gradually been brought under control, geopolitical risks (such as regional trade blocks) and the actual implementation of U.S. tariff policies continue to put pressure on the costs associated with supply chain relocation. While market uncertainty has been partially alleviated, high debt levels and protectionism remain key factors undermining economic confidence.
- (2) In 2025, the global notebook (NB) market saw shipments grow to 183 million units (up 4.9% Year-on-Year), driven by replacement demand following Microsoft's end of support for Windows 10. As we enter 2026, the market's growth momentum will shift from "mandatory device upgrades" to "AI-driven applications." Market research firms expect global notebook shipments to continue growing steadily. The key driver is that AI PC penetration is expected to exceed 40%. As NPU computing power improves and edge computing applications mature, notebooks will no longer be merely productivity tools but will also serve as personalized smart assistants. This trend will drive a significant increase in demand for high-performance transmission interfaces, high-frequency and high-speed cable assemblies, and precision electronic components, which will facilitate the market penetration of the Company's high-end products.
- (3) As AI applications extend from the cloud to edge devices (Edge AI), the connectivity industry is undergoing a transformative period for comprehensive upgrade in specifications. In 2026, the output value of the information and electronics industry is expected to continue the 10.33% growth as in the previous year. The key drivers of this growth are as follows:

1. Innovations in AI PC and High-Performance Interfaces: As the penetration rate of AI PC has increased, internal data transmission volumes have multiplied, driving the evolution of connectors toward high-frequency, high-speed transmission and high-power delivery. There is strong market demand for high-performance cable assemblies such as USB4 Gen 3/Gen 4 and Thunderbolt 5. Leveraging the technical expertise in high-frequency signal processing and precision machining, the Company is actively entering the AI device supply chain to enhance the products value.
 2. Edge AI Hardware and Server Peripherals: The widespread adoption of high-performance computing chips in server and edge computing hardware has driven growth in the market for high-speed backplane connectors and high-current cables. Our Company continues to invest in the research and development of more miniaturized, higher-density connectivity solutions to meet the demands of AI devices for slim profiles and high performance.
 3. Sustainable Supply Chains and Green Design: With the formal implementation of the EU Carbon Border Adjustment Mechanism (CBAM) in 2026, the connector industry is accelerating its adoption of post-consumer recycled (PCR) plastics and halogen-free materials. The Company will continue to optimize our green manufacturing processes, reduce the carbon footprint of our products through technological innovation, and ensure our competitive leadership within the global green supply chain.
- (4) The Company did not have any material events that would affect its financial and business affairs in the recent year due to domestic or foreign policies or laws and regulations.

To all shareholders, Ladies and Gentlemen
Good health and best of luck

JOINSOON ELECTRONICS MFG. CO., LTD.
Chairman: Huang, Ching-Hsiung

II. Corporate Governance Report

1. Information on directors, general managers, vice presidents, associates, and heads of departments and branches

(1) Profile of Directors and Supervisors

April 14, 2026

Title	Nationality or Place of Registration	Name	Gender Age	Date Elected	Term	Date First Elected	Shareholding when Elected		Current Shareholding		Current Shareholding Held by Spouse & Minor Children		Shareholding Held in the Name of Others		Education and Work Experience	Positions Concurrently Held at Other Companies	Executive, Director or Supervisor who Is Spouse or within the Second Degree of Kinship			Remark
							Shares	%	Shares	%	Shares	%	Shares	%			Title	Name	Relation	
Chairman	R.O.C.	Huang, Chin-Hsiung	Male 71-80	May 29, 2025	3 years	March 25, 1977	5,706,268	5.31	6,458,753	4.69	1,717	0.00	0	0.00	<ul style="list-style-type: none"> American Commonwealth University MBA General Manager of BEST Technology Co., Ltd. President of the Far East Rotary Club 	<ul style="list-style-type: none"> Director of Joinson Electronics Manufacturing Co., (Thailand) Ltd. and Plant manager in Thailand plant. Representative of Corporate Director, Teamplus Technology Inc. 	Vice President	Huang, Chin-Chi	Second degree	None
Vice President	R.O.C.	Huang, Chin-Chi	Male 61-70	May 29, 2025	3 years	December 25, 2002	4,154,933	3.86	5,028,465	3.65	0	0.00	0	0.00	<ul style="list-style-type: none"> Advanced MBA of Beijing Tsinghua University, Shenzhen Branch. Vice President of Best Digital Technology Corp. Representative of the Corporate Director of Teamplus Technology Inc. 	<ul style="list-style-type: none"> General manager of Joinson Electronics Manufacturing Co., Ltd. General manager of Dongguan Joinson Electronics Manufacturing Co., Ltd. Director of Joinson Electronics Manufacturing Co., (Thailand) Ltd. Owner of Dongguan Jianyi Electronic Technology Co., Ltd. 	Chairman	Huang, Chin-Hsiung	Second degree	None
Independent Director	R.O.C.	Chuang, Te-Min (Note)	Male 71-80	May 29, 2025	3 years	June 24, 2005	91	0.00	91	0.00	0	0.00	0	0.00	<ul style="list-style-type: none"> Graduated from the Department of Electrical Engineering, Ming Chi Institute of Technology Vice President of Chuanhua Precision Corp. 	<ul style="list-style-type: none"> None 	None	None	None	None
Independent Director	R.O.C.	Chen, I-Hsun	Male 61-70	May 29, 2025	3 years	June 16, 2022	0	0.00	0	0.00	0	0.00	0	0.00	<ul style="list-style-type: none"> Graduated from the Department of Business, Li-Te Commercial & Industrial Vocational School 	<ul style="list-style-type: none"> Chairman of S.Y.C. Vino & Cigar Company Director of Papelera Commercial (Taiwan) Ltd. 	None	None	None	None
Independent Director	R.O.C.	Hsu, Mei-Man	Female 61-70	May 29, 2025	3 years	May 29, 2025	0	0.00	0	0.00	0	0.00	0	0.00	<ul style="list-style-type: none"> Ph.D., Department of Accounting and Information Technology, National Chung Cheng University Accountant of Being Honor CPA Firm Adjunct Associate Professor, Department of Accounting, Ming Chuan University Adjunct Lecturer, National Taipei University 	<ul style="list-style-type: none"> Accountant of Being Honor CPA Firm Adjunct Associate Professor, Department of Accounting, Ming Chuan University Adjunct Lecturer, National Taipei University 	None	None	None	None

Note: Chuang, Te-Min was first elected as Independent Director for the period from June 24, 2005 to June 24, 2007 (less than one full term), second elected as Independent Director for the period from June 11, 2020 to June 10, 2022, and third elected as Independent Director for the period from June 16, 2022 to June 15, 2025.

(2) Directors are major shareholders of corporate shareholders: None

(3) Disclosure of Directors' Professional Qualifications and Independent Directors' Independence Information

Qualifications	Professional Qualification and Experience	Independence Status (Note)	Number of Other Public Companies where the Individual Concurrently Serves as Independent Director
Name			
Chairman Huang, Chin-Hsiung	Has more than five years of working experience required for the business of the Company and is currently serving as the Chairman of the Company and has not been subject to any of the provisions of Article 30 of the Companies Act.	Not applicable	None
Vice President Huang, Chin-Chi	Has more than five years of working experience required for the business of the Company and is currently serving as the Vice President of the Company and has not been subject to any of the provisions of Article 30 of the Companies Act.	Not applicable	None
Independent Director Chuang, Te-Min	Has more than five years of working experience in the company's industry and business knowledge required, served as a vice president of Chuanhua Precision Corp. and has not been subject to any of the provisions of Article 30 of the Companies Act.	Complied with the 12 requirements listed in the independence of the Company's Board of Directors for the two years prior to his election and during his tenure of office.	None
Independent Director Chen, I-Hsun	Has more than five years of working experience in the company's industry and business knowledge required, currently serves as the chairman of the board of directors of S.Y.C. Vino & Cigar Company, a director of Papelera Commercial (Taiwan) Ltd. and has not been subject to any of the provisions of Article 30 of the Companies Act.	Complied with the 12 requirements listed in the independence of the Company's Board of Directors for the two years prior to his election and during his tenure of office.	None
Independent Director Hsu, Mei-Man	Has more than five years of working experience in corporate industry, business, finance and accounting knowledge required, and currently serves as an accountant of Being Honor CPA Firm, and has not been subject to any of the provisions of Article 30 of the Companies Act.	Complied with the 12 requirements listed in the independence of the Company's Board of Directors for the two years prior to his election and during his tenure of office.	None

Note: The independence status of each director in the two years prior to their election and during their term of office (the compliance is disclosed in the above table).

- (1) Not an employee of the Company or any of its affiliates.
- (2) Not a director or supervisor of the Company or its affiliate. (However, this does not apply in a case where the person is also an independent director of the Company and its parent or subsidiary or a subsidiary of the same parent in accordance with the Act or the laws and regulations of the local country).
- (3) Not a natural-person shareholder who holds shares, together with those held by the person's spouse and minor children or held by the person under others' names, in an aggregate amount of 1% or more of the total number of outstanding shares of the Company or who is ranked in the top 10 in terms of shareholding.
- (4) Not a spouse, a relative within the second degree of kinship, or a relative within the third degree of kinship of a person other than a manager listed in (1) or a person listed in (2) or (3).
- (5) Not a director, supervisor, or employee of an institutional shareholder that directly holds 5% or more of the total number of shares issued by the Company, that is ranked in the top 5 in terms of shareholding, or that appoints the representative to serve as the director or supervisor 15 in accordance with Paragraph 1 or 2, Article 27 of the Company Act. (However, this does not apply in a case where the person is also an independent director of the Company and its parent or subsidiary or a subsidiary of the same parent in accordance with the Act or the laws and regulations of the local country).
- (6) Not a director, supervisor or employees of another Company where the same person controls a majority of the Company's directors or shares with voting rights. (However, this does not apply in a case where the person is also an independent director of the Company and its parent or subsidiary or a subsidiary of the same parent in accordance with the Act or the laws and regulations of the local country).
- (7) Not a director, supervisor or employee of another Company or institution who or whose spouse is also the Chairman, the General Manager or an equivalent position of the Company. (However, this does not apply in a case where the person is also an independent director of the Company and its parent or subsidiary or a subsidiary of the same parent in accordance with the Act or the laws and regulations of the local country).
- (8) Not a director, supervisor, managerial officer, or shareholder holding 5% or more of the shares of a specific Company or institution that has financial or business relations with the Company. (However, this does not apply in a case where a specific Company or institution holds more than 20% but less than 50% of the total shares issued by the Company and also serves as an independent director of the Company and its parent or subsidiary or a subsidiary of the same parent in accordance with the Act or the laws and regulations of the local country).
- (9) Not a professional individual, sole proprietor, or partner or an owner, partner, director, supervisor, or managerial officer or a spouse thereof of a Company or institution providing auditing or commercial, legal, financial, accounting services or consultations for the Company or its affiliate with a cumulative remuneration less than NT\$500,000 in the past two years. However, this does not apply in a case where a member on the Remuneration Committee, the Review Committee for Public Tender Offer or the Special Committee for Mergers and Acquisitions who performs the duties in accordance with the Securities and Exchange Act or the Business Mergers and Acquisitions Act.
- (10) Not a spouse or relative within the second degree of kinship to any other director of the Company.
- (11) Not having any of the conditions defined in Article 30 of the Company Act.
- (12) Not a governmental or judicial person or its representative as defined in Article 27 of the Company Act.

(4) Board Diversity and Independence :

1. The Board's Diversity Policy, Goals and Status of Achievement

(1) Diversity on the Board :

Based on the Company's policy of diversification, strengthening corporate governance and promoting the development of a sound board of directors composition and structure, the Company adopts a candidate nomination system in accordance with the Company's Articles of Incorporation, evaluates each candidate's academic qualifications, professional background, integrity or relevant professional qualifications, and then submits the

nomination to the shareholders' meeting for election after the Board of Directors' meeting passes a resolution. Directors as the employees account for 40% of the Board of Directors, while independent directors account for 60%. Due to the nature of the industry and historical factors, the Company has not set specific proportional requirements when appointing directors in the past, instead prioritizing professional competence and experience. The Company shall formulate appropriate diversification policies based on our own operations, business model, and development needs, including, but not limited to, the following:

A. Basic criteria and values: gender, age, nationality and culture, etc.

B. Expertise and skills: Professional background (e.g., law, accounting, industry, finance, marketing, or technology), professional skills, and industry experience.

Board members should generally possess the knowledge, skills and qualities necessary to carry out their duties. In order to achieve the desired objectives of corporate governance, the Board as a whole should possess the following competencies:

A. Operating judgment ability.

B. Accounting and financial analysis ability.

C. Management ability.

D. Crisis management ability.

E. Industrial knowledge.

F. International market view.

G. Leadership ability.

H. Decision-making ability.

Among the Board of Directors, 40% are employees and 60% are independent directors. Due to the industry characteristics and historical factors, the Company selected directors based on their professional ability and experience and has not set a specific percentage requirement. Although there is currently only one female director, we are actively seeking female professionals with industry experience to join us in the future. We have established an internal female talent development program to strengthen the career development of senior female management in order to increase the number of candidates for future directors. The diversity of the Board of Directors is as follows:

Name of Director		Diversified core items	Gender	Nationality	Concurrent Employee	Age				Professional Background				Professional Knowledge and Skills						
						41-50	51-60	61-70	71-80	Finance & Accounting	Industry	Information & Technology	Law	Operating judgment ability	Operating management	Leadership Decision-	Crisis Management ability	Industrial knowledge	International market view	
Director	Huang, Chin-Hsiung		Male	R.O.C	v	-	-	-	v	-	v	v	-	v	v	v	v	v	v	
Director	Huang, Chin-Chi		Male		v	-	-	v	-	-	v	v	-	v	v	v	v	v	v	v
Independent Director	Chuang, Te-Min		Male		-	-	-	-	v	-	v	v	-	v	v	v	v	v	v	v
Independent Director	Chen, I-Hsun		Male		-	-	-	v	-	-	v	v	-	v	v	v	v	v	v	v
Independent Director	Hsu, Mei-Man		Female		-	-	v	-	-	-	v	v	v	-	v	v	v	v	v	v

2. Independence of the Board :

The election process of all directors of the Company is open and fair, and is in compliance with the Company's 'Articles of Incorporation' and 'Code of Corporate Governance Practices'. The current structure of the Board of Directors is composed of 3 independent directors (60%) and 2 non-independent directors (40%), respectively. Elected by the candidate nomination system. During the nomination and selection of the Board of Directors, the Company obtained written statements, work experience, proof of current employment, and family relationship forms from each director to verify that he/she, his/her spouse, and his/her relatives up to the third degree are independent of the Company; and also verified that the three independent directors have complied with the requirements of the 'Public Offering Regulations' issued by the Financial Supervisory Commission (FSC) for the two years prior to the election of the three independent directors, as well as the period of their service in the Company. In addition, it was verified that all three independent directors met the qualifications set forth in the 'Regulations Governing the Establishment and Compliance of Independent Directors of Public Companies' promulgated by the Financial Supervisory Commission and in Article 14-2 of the Securities and Exchange Act, and that the independent directors have been able to independently perform their duties in accordance with the power to participate in decision-making and expression of opinions conferred by Article 14-3 of the Securities and Exchange Act.

(4) General Manager, Vice Presidents, Associates, and Heads of All Departments and Branches

April 14, 2026

Title	Nationality	Name	Gender	Date of appointment	Shareholding		Shareholding Held by Spouse & Minor Children		Shareholding Held in the Name of Others		Major Experience (Education)	Positions Concurrently Held at Other Companies	Other manager who is the spouse or a relative within second degree			Note
					Number of shares	Shareholding %	Number of shares	Shareholding %	Number of shares	Shareholding %			Title	Name	Relationship	
General Manager	R.O.C.	Huang, Chin-Chi	Male	January 30, 2013	5,028,465	3.65	0	0.00	0	0.00	<ul style="list-style-type: none"> Advanced MBA of Beijing Tsinghua University, Shenzhen Branch. Vice President of Best Digital Technology Corp. Representative of the Corporate Director, Teamplus Technology Inc. 	<ul style="list-style-type: none"> Director of Joinsoon Electronics Manufacturing Co., (Thailand) Ltd. General manager of Dongguan Joinsoon Electronics Manufacturing Co., Ltd. Owner of Dongguan Jianyi Electronic Technology Co., Ltd. 	Plant Manager in Thailand	Huang, Chin-Hsiung	Second degree	Note
Plant Manager (Thailand plant)	R.O.C.	Huang, Chin-Hsiung	Male	January 1, 2012	6,458,753	4.69	1,717	0.00	0	0.00	<ul style="list-style-type: none"> American Commonwealth University MBA General Manager of BEST Technology Co., Ltd. President of the Far East Rotary Club 	<ul style="list-style-type: none"> Director of Joinsoon Electronics Manufacturing Co., Ltd. and Plant Manager (Thailand plant) Representative of Corporate Director, Teamplus Technology Inc. 	General Manager	Huang, Chin-Chi	Second degree	Note
General Manager	R.O.C.	Lin, Wu-Chi	Male	January 30, 2013	190,850	0.14	0	0.00	0	0.00	<ul style="list-style-type: none"> Graduated from Electrical Engineering department of National Central University. General manager and director of Horten Technology Corporation Vice President of Business Division, Speed Tech Corp. Vice President of Business Division, Joinsoon Electronics Manufacturing Co., Ltd. 	None	None	None	None	None
Vice President	R.O.C.	Hsieh, Pei-Fei	Female	July 1, 2021	71,196	0.05	0	0.00	0	0.00	<ul style="list-style-type: none"> B.S., Department of International Trade, Takming University of Science and Technology Senior Director, Marketing Business Unit, Connectivity Components Business Group of Joinsoon Electronics Manufacturing Co., Ltd. 	None	None	None	None	None
Vice President	R.O.C.	Peng, Yu-Wei	Male	June 1, 2025	200,000	0.15	0	0.00	0	0.00	<ul style="list-style-type: none"> Master of Science in Electronics, Ming Hsin 	None	None	None	None	None

Title	Nationality	Name	Gender	Date of appointment	Shareholding		Shareholding Held by Spouse & Minor Children		Shareholding Held in the Name of Others		Major Experience (Education)	Positions Concurrently Held at Other Companies	Other manager who is the spouse or a relative within second degree			Note
					Number of shares	Shareholding %	Number of shares	Shareholding %	Number of shares	Shareholding %			Title	Name	Relationship	
											University of Science and Technology • Assistant Manager, Research and Development Unit, Connectivity Components Business Group of Joinsoon Electronics Manufacturing Co., Ltd. • Vice President of Engineering, R&D Center, VSO ELECTRONICS CO., LTD.					
Vice President	R.O.C.	Lo, Jung-Tsang	Male	January 1, 2020	335,737	0.24	0	0.00	0	0.00	• Graduated from Department of Mechanical Engineering, Minghsin College of Technology • Assistant Manager of Cheng Uei Precision Industry Co., Ltd. • Manager of Connection Components Division, Joinsoon Electronics Manufacturing Co., Ltd.	• People in Charge of Suzhou Jianho Precision Electronics Co., Ltd.	None	None	None	None
Vice President	R.O.C.	Ou, Keng-Hung	Male	January 1, 2024	69,000	0.05	0	0.00	0	0.00	• Graduate of Department of Accounting, National Taiwan University • Associate in the Audit Department of KPMG. • Finance & Accounting Manager of Protech Wheel Industry Co., Ltd. • Finance & Accounting Manager of Baotou Wheel tech Aluminum Co., Ltd.	• Director of Joinsoon Electronics Manufacturing Co., (Thailand) Ltd.	None	None	None	None
Associate	R.O.C.	Kuo, Shuan-Hsu	Male	March 1, 2016	100,174	0.07	0	0.00	0	0.00	• Graduated from Department of Mechanical Engineering, Lughwa College of Technology. • Manager of SMT Department, Globefan Technology Co., Ltd. • Manager of SMT Department, Joinsoon Electronics Manufacturing Co., Ltd.	None	None	None	None	None
Associate	R.O.C.	Hsieh,	Male	March 1,	9,648	0.01	0	0.00	0	0.00	• Graduated from Department of	None	None	None	None	None

Title	Nationality	Name	Gender	Date of appointment	Shareholding		Shareholding Held by Spouse & Minor Children		Shareholding Held in the Name of Others		Major Experience (Education)	Positions Concurrently Held at Other Companies	Other manager who is the spouse or a relative within second degree			Note
					Number of shares	Shareholding %	Number of shares	Shareholding %	Number of shares	Shareholding %			Title	Name	Relationship	
		Ui-Chun		2016							Electronics, National Taipei University of Technology. • Manager of SMT Department, Joinsoon Electronics Manufacturing Co., Ltd.					
Associate	R.O.C.	Chiu, Ching-Min	Male	July 1, 2021	30,000	0.02	0	0.00	0	0.00	• Graduated from the Department of Electrical Engineering, Ta Hwa University of Science and Technology • Deputy Director, Optical Cable Division of Dongguan Joinsoon Electronics Mfg. Co., Ltd.	None	None	None	None	None
Associate	R.O.C.	Lin, Ching-Hung	Male	January 1, 2024	31,000	0.02	0	0.00	0	0.00	• Graduated from the Department of Accounting, Fu Jen Catholic University • Manager, Operations Management Department of Cheng Uei Precision Industry Co., Ltd. • Deputy Director, Division of Accounting of Joinsoon Electronics Manufacturing Co., Ltd.	None	None	None	None	None
Associate	R.O.C.	Hsieh, Wei-Hua	Female	January 1, 2024	31,054	0.03	0	0.00	0	0.00	• Graduated from the Business Administration, Sun Yat-sen University • Deputy Director, Administration Division of Joinsoon Electronics Manufacturing Co., Ltd.	None	None	None	None	None
Associate	R.O.C.	Liang, Zheng-Yin	Male	January 1, 2026	20,183	0.01	8,901	0.01	0	0.00	• Graduated from the Department of Mechanical Engineering, National Taipei University of Technology • Deputy Director of the Engineering Department of Joinsoon Electronics Mfg. Co., Ltd.	None	None	None	None	None

2. Remuneration paid to directors, supervisors, general manager and vice president for the most recent year

(1) Remuneration to General Directors and Independent Directors

Unit : NTD thousand

Title	Name	Director Remuneration								Ratio of Total Remuneration (A+B+C+D) to Net Income after tax (%)		Adjunct employees received related remuneration						Ratio of Total Remuneration (A+B+C+D+E+F+G) to Net Income after tax (%)		Received remuneration from a re-invested business other than a subsidiary or from the parent company		
		Remuneration (A)		Severance Pay and Pension (B)		Directors' Remuneration (C)		Professional Practice Fee (D)				Salary, bonus and special allowance (E)		Severance Pay and Pension (F)		Employee remuneration (G)						
		The company	All Companies in Financial Statements	The company	All Companies in Financial Statements	The company	All Companies in Financial Statements	The company	All Companies in Financial Statements	The company	All Companies in Financial Statements	The company	All Companies in Financial Statements	The company		All Companies in Financial Statements		The company	All Companies in Financial Statements			
Chairman	Huang, Chin-Hsiung	0	0	0	0	0	0	0	0	0.00%	0.00%	5,039	6,014	0	0	0	0	0	0	5,039 (4.32%)	6,014 (5.15%)	0
Vice President	Huang, Chin-Chi	0	0	0	0	0	0	0	0	0.00%	0.00%	2,659	4,456	0	0	0	0	0	0	2,659 (2.28%)	4,456 (3.82%)	0
Independent Director	Chen, I-Hsun	0	0	0	0	0	0	730	730	730 (0.63%)	730 (0.63%)	0	0	0	0	0	0	0	0	730 (0.63%)	730 (0.63%)	0
Independent Director	Chuang, Te-Min	0	0	0	0	0	0	720	720	720 (0.62%)	720 (0.62%)	0	0	0	0	0	0	0	0	720 (0.62%)	720 (0.62%)	0
Independent Director (Note 1)	Hsu, Mei-Man	0	0	0	0	0	0	600	600	600 (0.51%)	600 (0.51%)	0	0	0	0	0	0	0	0	600 (0.51%)	600 (0.51%)	0
Independent Director (Note 2)	Shen, Hsiao-Ling	0	0	0	0	0	0	560	560	560 (0.48%)	560 (0.48%)	0	0	0	0	0	0	0	0	560 (0.48%)	560 (0.48%)	0

Note 1: Independent Director, Hsu, Mei-Man was elected on May 29, 2025.

Note 2: Independent Director, Shen, Hsiao-Ling stepped down upon the expiration of her term on May 29, 2025.

The Company's policy, system, standards and structure for the remuneration of independent directors, and the relevance to the amount of remuneration according to the responsibilities, risks and time commitment of the directors: The remuneration of all directors (including independent directors) is determined by the Board of Directors in accordance with the Company's Articles of Incorporation, and is based on the level of participation and the value of contribution of individual directors, with reference to industry standards. In addition, if the Company makes a profit in the current year, the Board of Directors shall resolve to set aside less than 3% as the remuneration of the directors in accordance with the Company's Articles of Incorporation. The Company periodically evaluates the performance of the Board of Directors in accordance with the "Board of Directors' Performance Evaluation Method", and the reasonableness of the performance evaluation and remuneration is reviewed by the Salary and Remuneration Committee and the Board of Directors.

1. Besides those disclosed in the above table, the remuneration received by Directors from all consolidated entities in recently years for providing service (Remunerations received as consultants for non-employees of the parent company/ of all companies/transferred investment enterprises listed in the financial report, etc.) : None.

Range of Remuneration

Range of Remuneration Paid to Directors	Name of Directors			
	Total amount of the first four remunerations (A+B+C+D)		Total amount of the first seven remunerations (A+B+C+D+E+F+G)	
	The Company	All Companies in Financial Statements	The Company	All Companies in Financial Statements
Less than NT\$1,000,000	Huang, Chin-Hsiung Huang, Chin-Chi Chen, I-Hsun Chuang, Te-Min Hsu, Mei-Man Shen, Hsiao-Ling	Huang, Chin-Hsiung Huang, Chin-Chi Chen, I-Hsun Chuang, Te-Min Hsu, Mei-Man Shen, Hsiao-Ling	Chen, I-Hsun Chuang, Te-Min Hsu, Mei-Man Shen, Hsiao-Ling	Chen, I-Hsun Chuang, Te-Min Hsu, Mei-Man Shen, Hsiao-Ling
NT\$1,000,000 (inclusive) ~ NT\$2,000,000 (exclusive)				
NT\$2,000,000 (inclusive) ~ NT\$3,500,000 (exclusive)			Huang, Chin-Chi	
NT\$3,500,000 (inclusive) ~ NT\$5,000,000 (exclusive)				Huang, Chin-Chi
NT\$5,000,000 (inclusive) ~ NT\$10,000,000 (exclusive)			Huang, Chin-Hsiung	Huang, Chin-Hsiung
NT\$10,000,000 (inclusive) ~ NT\$15,000,000 (exclusive)				
NT\$15,000,000 (inclusive) ~ NT\$30,000,000 (exclusive)				
NT\$30,000,000 (inclusive) ~ NT\$50,000,000 (exclusive)				
NT\$50,000,000 (inclusive) ~ NT\$100,000,000 (exclusive)				
More than NT\$100,000,000				
Total	6 people	6 people	6 people	6 people

(2) Remuneration to General Manager and Vice Presidents :

Unit : NTD thousand

Title	Name	Salary (A)		Severance Pay and Pension (B)		Bonus and Special Allowance (C)		Employee Remuneration (D)				Ratio of Total Remuneration (A+B+C+D) to Net Income after- tax (%)		Receive remuneration from a re-invested business other than a subsidiary or from the parent company
		The Company	All Companies in Financial Statements	The Company	All Companies in Financial Statements	The Company	All Companies in Financial Statements	The Company		All Companies in Financial Statements		The Company	All Companies in Financial Statements	
								Cash Bonus Amount	Stock Bonus Amount	Cash Bonus Amount	Stock Bonus Amount			
General Manager	Huang, Chin-Chi	2,659	4,456	0	0	0	0	0	0	0	0	2,659 (2.28%)	4,456 (3.82%)	None
Plant Manager (Thailand plant)	Huang, Chin-Hsiung	3,775	4,750	0	0	1,264	1,264	0	0	0	0	5,039 (4.32%)	6,014 (5.15%)	None
Business Group General Manager	Lin, Wu-Chi	3,351	3,351	0	0	139	139	0	0	0	0	3,490 (2.99%)	3,490 (2.99%)	None
Vice President	Hsieh, Pei-Fei	3,603	3,603	0	0	650	650	0	0	0	0	4,253 (3.64%)	4,253 (3.64%)	None
Vice President	Lo, Jung-Tsang	0	2,147	0	0	278	278	0	0	0	0	278 (0.24%)	2,425 (2.08%)	None
Vice President	Ou, Keng-Hung	2,739	2,739	0	0	178	178	0	0	0	0	2,917 (2.50%)	2,917 (2.50%)	None
Vice President	Peng, Yu-Wei	1,374	1,374	0	0	750	750	0	0	0	0	2,124 (1.82%)	2,124 (1.82%)	None

Range of Remuneration

Range of Remuneration Paid to General Manager and Vice Presidents	Name of General Manager and Vice President	
	The Company	All Companies in Financial Statements
Less than NT\$1,000,000	Lo, Jung-Tsang	
NT\$1,000,000 (inclusive) ~ NT\$2,000,000 (exclusive)		
NT\$2,000,000 (inclusive) ~ NT\$3,500,000 (exclusive)	Huang, Chin-Chi Lin, Wu-Chi Peng, Yu-Wei Ou, Keng-Hung	Lin, Wu-Chi Lo, Jung-Tsang Peng, Yu-Wei Ou, Keng-Hung
NT\$3,500,000 (inclusive) ~ NT\$5,000,000 (exclusive)	Huang, Chin-Hsiung Hsieh, Pei-Fei	Huang, Chin-Chi Hsieh, Pei-Fei
NT\$5,000,000 (inclusive) ~ NT\$10,000,000 (exclusive)	Huang, Chin-Hsiung	Huang, Chin-Hsiung
NT\$10,000,000 (inclusive) ~ NT\$15,000,000 (exclusive)		
NT\$15,000,000 (inclusive) ~ NT\$30,000,000 (exclusive)		
NT\$30,000,000 (inclusive) ~ NT\$50,000,000 (exclusive)		
NT\$50,000,000 (inclusive) ~ NT\$100,000,000 (exclusive)		
More than NT\$100,000,000		
Total	7 people	7 people

(4) Remuneration of executives with the top five highest remuneration:

Title	Name	Salary (A)		Severance Pay and Pension (B)		Bonus and Special Allowance (C)		Employee Remuneration (D)				Ratio of Total Remuneration (A+B+C+D) to Net Income after-tax (%)		Receive remuneration from a re-invested business other than a subsidiary or from the parent company
		The Company	All Companies in Financial Statements	The Company	All Companies in Financial Statements	The Company	All Companies in Financial Statements	The Company		All Companies in Financial Statements		The Company	All Companies in Financial Statements	
								Cash Bonus Amount	Stock Bonus Amount	Cash Bonus Amount	Stock Bonus Amount			
Plant Manager (Thailand plant)	Huang, Chin-Hsiung	3,775	4,750	0	0	1,264	1,264	0	0	0	0	5,039 (4.32%)	6,014 (5.15%)	None
Vice President	Hsieh, Pei-Fei	3,603	3,603	0	0	650	650	0	0	0	0	4,253 (3.64%)	4,253 (3.64%)	None
General Manager	Huang, Chin-Chi	2,659	4,456	0	0	0	0	0	0	0	0	2,659 (2.28%)	4,456 (3.82%)	None
Business Group General Manager	Lin, Wu-Chi	3,351	3,351	0	0	139	139	0	0	0	0	3,490 (2.99%)	3,490 (2.99%)	None
Vice President	Ou, Keng-Hung	2,739	2,739	0	0	178	178	0	0	0	0	2,917 (2.50%)	2,917 (2.50%)	None

- (5) The name of the manager who allocated the employees' remuneration in the most recent year and the distribution status: No employee dividends were allocated in 2025.
- (6) An analysis of the total remuneration paid to the Company's directors, supervisors, general manager and deputy general manager as a ratio of the individual or individual net income of the Company's financial statements for the last two years, and an explanation of the policy, standard and package of remuneration, the process of setting remuneration, and the correlation with operating performance and future risks
1. Analysis of total remuneration paid to the Company's directors, supervisors, general manager and vice president as a ratio of net income after tax of the Company and all companies in the consolidated financial statements for the most recent two years

Unit : NTD thousand ; %

Title	FY 2024				FY 2025			
	Total remuneration		Ratio of net income after tax to individual or separate financial statements		Total remuneration		Ratio of net income after tax to individual or separate financial statements	
	The Company	All Companies in Financial Statements	The Company	All Companies in Financial Statements	The Company	All Companies in Financial Statements	The Company	All Companies in Financial Statements
Directors	10,355	13,127	(10.24%)	(12.98%)	10,308	13,080	(8.83%)	(11.21%)
General Manager and Vice President	18,576	23,595	(18.37%)	(23.33%)	20,760	25,679	(17.78%)	(22.00%)

2. The correlation between the policy and procedures of remuneration and the operating performance and future risks

The directors' remuneration is determined by the Remuneration Committee and Board of Directors in accordance with Article 21 of the Company's Articles of Incorporation, and is based on the level of participation and the value of contribution in the operation, with reference to industry standards. In addition, if the Company makes a profit in the current year, 5% to 15% shall be set aside as remuneration to employees and not more than 3% as remuneration to directors and supervisors in accordance with Article 24 of the Company's Articles of Incorporation. However, if the Company has accumulated losses, the amount of compensation shall be reserved in advance.

The remuneration to directors (including independent directors) has taken into consideration the level of participation in the operation and their performance. The consideration includes:

Consideration	Description
Mastery of the company's objectives and tasks	<ol style="list-style-type: none"> 1. Clearly understand the company's core values. 2. Clearly understand all the Company's strategic objectives as set by the Board of Directors. 3. Clearly understand the characteristics and risks of the industry in which the Company operates.
Awareness of duties and responsibilities	<ol style="list-style-type: none"> 1. Understand their responsibilities and familiar with the operations of the Company. 2. Do follow the obligation of confidentiality with respect to the environment and relevant information within the Company obtained when performing their duties.
Participation in the operation	<ol style="list-style-type: none"> 1. Physical attendance at Board meetings. 2. Read and understand the meeting materials before the meeting so as to be able to fully perform their duties during the meeting. 3. Effective contribution to the Board of Directors, and the actual assessment and supervision of the Company's existing or potential risks.
Management of internal relations and communication	<ol style="list-style-type: none"> 1. Have good interaction with the management team. 2. Have good communication with other Directors. 3. Adequate communicate and exchange with the accountants.
Professional and continuing education	<ol style="list-style-type: none"> 1. Have the necessary expertise to make decisions. 2. Continuously strengthen professional knowledge and skills.
Internal control	<ol style="list-style-type: none"> 1. Has effectively evaluated and monitored the effectiveness of internal control systems and risk management. 2. Understand and monitor the company's accounting system, financial status and financial reports, audit reports and their tracking.

The remuneration to managers has taken into consideration their performance, management methods and attitudes, and communication and coordination skills. The consideration includes:

Consideration	Description
Performance	<ol style="list-style-type: none"> 1. Decision Making / Forward Thinking Strategy / Planning and Execution / Analytical Judgment / Innovation and Change. 2. Cost awareness and supervision / Resource allocation / Customer orientation. 3. Achievement rate of policy.
Management methods and attitudes	<ol style="list-style-type: none"> 1. Shared values conformity. 2. Good cadres principle conformity.
Communication and coordination skills	<ol style="list-style-type: none"> 1. Interdepartmental coordination satisfaction. 2. Effectively lead the department in aligning with the company's vision to exceed goals / Crisis management / Teamwork / Big-picture focus.

3. Corporate Governance Status

(1) Operation of the Board of Directors

1. A total of 6 (A) meetings of the Board of Directors were held in FY 2025. The attendance of director and supervisor were as follows :

Title	Name	Times of Attendance in Person B	Times of Attendance by Proxy	Attendance rate in person (%) 【 B / A 】	Note
Chairman	Huang, Chin-Hsiung	8	-	100%	Re-elected
Director	Huang, Chin-Chi	8	-	100%	Re-elected
Independent Director	Hsu, Mei-Man	6	-	100%	Newly appointed on May 29, 2025
Independent Director	Chen, I-Hsun	8	-	100%	Re-elected
Independent Director	Chuang, Te-Min	8	-	100%	Re-elected
Independent Director	Shen, Hsiao-Ling	2	-	100%	Term expired on May 29, 2025

Other matters to be recorded :

1. If any of the following circumstances occurs in the operation of the board meeting, please indicate the date of the board meeting, the session number, the contents of the motion, the opinions of all independent Directors and the Company's handling of the opinions of the Independent Directors :

(1) Matters listed in Article 14-3 of the Securities Exchange Act: The Company has established an audit committee, and the provisions of Article 14-3 are not applicable, please refer to the 'Operation of Audit Committee' in this annual report for the relevant provisions.

(2) Other than the foregoing, other resolutions of the Board of Directors that are opposed or qualified by the independent directors and for which records or written statements are available: None.

2. For the situation where a Director avoids a motion related to his/her own interests, please specify the Director's names, the contents of the motion, the reasons for the avoidance of interests and the voting results:

Date of Board Meeting	Name of Director	Content of the motion	Reasons for avoidance of interest	Voting Results
March 10, 2025	Huang, Chin-Hsiung Huang, Chin-Chi Chen, I-Hsun Chuang, Te-Min	1. Nomination and consideration of candidates for Director/Independent Director.	All interested directors recused themselves from participating in the discussion and voting in accordance with the law.	Not participating in the vote
June 27, 2025	Chen, I-Hsun Chuang, Te-Min Hsu, Mei-Man	1. Proposal to appoint members of the sixth Remuneration Committee. 2. Proposal to appoint members of the second Nominating, Corporate Governance and Sustainability Committee.	All interested directors recused themselves from participating in the discussion and voting in accordance with the law.1.	
July 21, 2025	Chen, I-Hsun Chuang, Te-Min Hsu, Mei-Man	1. Remuneration of Independent Directors and Functional Committees.	All interested directors recused themselves from participating in the discussion and voting in accordance with the law.	Not participating in the vote

3. Information on the cycle and period, scope, method, and content of the Board' self-evaluation of the Company.

Evaluation cycle	Evaluation Period	Scope of Evaluation	Evaluation Method	Content of Evaluation
Once a year	2025/01-2025/12	Performance Evaluation of the Board of Directors	Internal self-evaluation by the Board of Directors	Included are the level of participation in the Company's operations, the quality of decisions made by the Board of Directors, the composition and structure of the Board of Directors, the selection and continuing education of directors, and internal control.
Once a year	2025/01-2025/12	Performance evaluation of individual board members	Self-evaluation by Board Members	Included are the mastery of the company's objectives and tasks, the directors' awareness of their duties and responsibilities, their participation in the company's operations, the management of internal relations and communication, the directors' professional and continuing education, and internal control.
Once a year	2025/01-2025/12	Performance Evaluation of Salary and Remuneration Committee	Self-evaluation of Salary and Remuneration Committee Members	Included are the level of participation in the company's operation, the recognition of the duties of the remuneration committee, the improvement of the decision quality of the remuneration committee, the composition and selection of the remuneration committee members, and the internal control.
Once a year	2025/01-2025/12	Performance Evaluation of Audit Committee	Self-evaluation of audit committee members	Included are the level of participation in the company's operation, awareness of the audit committee's responsibilities, improvement of the quality of the audit committee's decision making, composition and selection of audit committee members, and internal control.
Once a year	2025/01-2025/12	Performance Evaluation of Nominating, Corporate Governance and Sustainability Committee	Self-evaluation of audit committee members	Included are the level of participation in the company's operation, awareness of the nomination, corporate governance and sustainability committee, improvement of the quality of decision-making by the nomination, corporate governance and sustainability committee, composition and selection of the nomination, corporate governance and sustainability committee, and internal control.

4. Evaluation of the current and most recent year's goals for strengthening the Board of Directors' functions (e.g., establishing an audit committee, enhancing information transparency, etc.) and evaluation of their implementation :

(1) Targets for strengthening of the functions of the Board of Directors

- A. Quarterly Board Meetings: The Board of Directors of the Company held eight board meetings in fiscal year 2025 and complied with the rule of procedures for board of directors' meetings to be held at least once every quarter.
- B. Information Disclosure and Enhancement of Information Transparency: Important motions are announced on Market Observation Post System (MOP) and disclosed on the Company's website in accordance with the law to ensure information disclosure and enhance information transparency in order to safeguard shareholders' rights and interests.
- C. Establishment of the Company's good board governance system, sound supervisory functions and strengthening of management functions: In accordance with the 'Board of Directors' Performance Evaluation Method' established by the Company, the results of the Board of Directors' evaluation were reported on 28 January 2026: the evaluation result for fiscal year 2025 was 99 points.
- D. Enhancement of operational knowledge and legal knowledge: The Company arranges external training courses for directors and supervisors from time to time, as well as training courses related to securities regulations; to enhance information transparency, the Company's auditors submit audit reports to the independent directors on a regular basis, and the independent directors communicate with the chief financial officer and auditors from time to time to understand the Company's operational status.
- E. The Company has established a Remuneration Committee responsible for assisting the Board of Directors in regularly evaluating and determining the remuneration of directors and managers, as well as regularly reviewing the policies, systems, criteria and structure of directors' and managers' remuneration.

- (2) Evaluation of Implementation Status: In order to implement corporate governance and enhance the functions of the Company's Board of Directors, the Company's Board of Directors approved the establishment of the 'Board of Directors' Performance Evaluation Method' on 21 March 2019; the performance evaluation method adopts two types of internal evaluation and external evaluation; the internal Board of Directors' performance evaluation shall be conducted at least once a year, and the evaluation may be conducted by an external professional independent organization or a team of external experts and scholars as necessary.

(2) Operation of the Audit Committee :

1. The Committee operates for the primary purpose of supervising the following matters:

- A. The fair presentation of the Company's financial statements.
- B. The selection, dismissal, independence and performance of the certified public accountants.
- C. The effective implementation of the Company's internal controls.
- D. The Company complies with relevant laws and regulations.
- E. Control of existing or potential risks of the Company.

2. 6 (A) meetings of the Audit Committee were held in 2025 and the attendance of the independent directors was as follows:

Title	Name	Times of Attendance in Person(B)	Times of Attendance by Proxy	Attendance rate in person (%) (B/A)	Note
Independent Director	Hsu, Mei-Man	4	-	100%	Newly appointed on May 29, 2025
Independent Director	Chen, I-Hsun	6	-	100%	Re-elected
Independent Director	Chuang, Te-Min	6	-	100%	Re-elected
Independent Director	Shen, Hsiao-Ling	2	-	100%	Term expired on May 29, 2025

Other matters to be recorded :

1.If the Audit Committee operates under any of the following circumstances, it shall state the date and term of the Audit Committee meeting, the content of the motion, the content of the objections, reservations or major recommendations of the independent directors, the results of the Audit Committee resolution, and the Company's handling of the Audit Committee's opinion.

(1) Matters listed in Article 14-5 of the Securities and Exchange Act:

Audit Committee	Content of the motion and follow-up	Matters listed in Article 14-5 of Securities and Exchange Law	Independent Directors' Opinion		
			Yes	No	Reserved opinion
The 16 th meeting of the 1st term March 10, 2025	The Individual and Consolidated Financial Reports for FY 2024.	√	√		
	Amendments to partial articles of the "Regulations Governing the Remuneration".	√	√		
	Amendments to Partial Articles of the Company's Articles of Incorporation'.	√	√		
	The Company intends to provide endorsement and guarantee for the financing from Land And House Bank Plc for the total credit line of Baht 50 million for the Company's 100% owned, Thai subsidiary Joinson Electronics Manufacturing Co., Ltd.	√	√		
	The 'Statement on Internal Control System' for FY 2024.	√	√		
	Handling of independent directors' opinions by the Company: None				
Resolution result: Approved by all committee members in attendance.					
The 1 st meeting of the 2nd term July 21, 2025	Amendments to "Procedures for the Preparation and Assurance of the Sustainability Report."	√	√		
	Handling of independent directors' opinions by the Company: None				
	Resolution result: Approved by all committee members in attendance.				
The 2 nd meeting of the 2nd term August 7, 2025	The consolidated financial statements for the 2nd quarter of 2025.	√	√		
	Amendments to partial articles of the "Procedures for Handling of Material Internal Information".	√	√		
	Handling of independent directors' opinions by the Company: None				
	Resolution result: Approved by all committee members in attendance.				
The 3 rd meeting of the 2nd term November 11, 2025	Proposal to provide a loan of US\$5,000,000 to the Company's subsidiary, Joinson Electronics Manufacturing Co., Ltd, for business needs.	√	√		
	Handling of independent directors' opinions by the Company: None				
	Resolution result: Approved by all committee members in attendance.				
The 4 th meeting of the 2nd term December 18, 2025	Independence and Suitability of Certified Public Accountants for the Company's Financial Reports	√	√		
	Public Subsidy Proposal for Accountants in 2025.	√	√		
	Amendments to partial articles of the "Rule of Procedures for Board of Directors' Meetings".	√	√		
	Proposal of 2025 capital increase by issuing common stock.	√	√		

(2) Except for the foregoing matters, other matters not approved by the Audit Committee and approved by two-thirds of all directors: None.

2.. Regarding recusals of independent directors from voting due to conflicts of interest, the names of the independent directors, contents of motions, reasons for recusal, and results of voting should be specified: None.

3. Communication between the independent directors and the head of internal audit and the accountant (should include the significant matters, methods and results of communication regarding the company's financial and business status):

- A. Before the end of each fiscal year, the audit plan for the following year will be communicated and discussed with the independent directors and submitted to the board of directors for resolution.
- B. The internal audit is conducted in accordance with the annual audit plan and the internal audit report is submitted to the independent directors for review by the end of the month following the date of completion of the audit. If the independent directors have any questions or instructions after reviewing the report, they will ask or inform the audit supervisor.
- C. Quarterly reports on the implementation of the audit plan are made to the Board of Directors. The independent directors communicate and discuss with the head of internal audit on various audit matters prior to the meeting.
- D. The evaluation of the effectiveness of the Company's internal control system and the statement of internal control system are submitted to the Audit Committee for review.
- E. The Company's annual financial report must be approved by at least one-half of all members of the Audit Committee before it is sent to the Board of Directors for resolution. The Audit Committee will arrange to invite the certified public accountants to give a full explanation of the audit results and the audit opinion to be issued before the review of the financial report is carried out.
- F. The Company's certified public accountants report the results of audits or reviews of financial statements and other communications required by relevant laws and regulations at the semi-annual meetings of the Audit Committee, and the members of the Audit Committee of the Company are in good communication with the certified public accountants.
- In summary, the independent directors can understand the operation status (including financial business status) and audit status of the Company through the audit reports provided by the Board of Directors and the Audit Committee as well as the Audit Unit on a regular basis, and can communicate well with the accountants through various reports and channels (e.g., telephone, facsimile, and e-mail, etc.).

(3) Corporate Governance Status, Deviations from the Corporate Governance Best Practice Principles for TWSE/TPEX Listed Companies and Reasons Evaluation Item Implementation Status Deviations from “the Corporate :

Evaluation Item	Implementation Status			Deviations from “the Corporate Governance Best-Practice Principles for TWSE/TPEX Listed Companies” and Reasons
	Yes	No	Abstract Illustration	
1. Does the Company follow the Corporate Governance Best Practice Principles for TWSE/ TPEX Listed Companies, and has the Company established and disclosed its own Corporate Governance Best Practice Principles?	√		The Company has established a "Corporate Governance Practice Statement" in accordance with the "Corporate Governance Practice Statement for TWSE/ TPEX Listed Companies".	No major difference.
2. The Company's shareholding structure and shareholders' equity				
(1) Has the Company set up internal operating procedures to handle shareholder proposals, doubts, disputes and litigation matters and followed the procedures?	√		(1) The Company has established 'Internal Procedures for Handling of Material Information' and has a spokesperson and a proxy spokesperson to deal with external statements and shareholders' proposals or disputes.	No major difference.
(2) Does the company have a list of the substantial shareholders and ultimate controllers of the substantial shareholders who actually control the company?	√		(2) The Company keeps track of the list of major shareholders who actually control the Company and has good relationship with them. In accordance with Article 25 of the Securities and Exchange Act, the Company reports changes in the shareholdings of insiders, including directors, supervisors, managers and shareholders whose shares exceed 10%, on a monthly basis on the website of the Market Observation Post System (MOPS) designated by the Securities and Futures Bureau.	No major difference.
(3) Has the Company established and implemented risk management and firewall mechanisms with its affiliates?	√		(3) The Company and its affiliates are treated in accordance with the "Regulations Governing Intercompany Financial Operations of Affiliates".	No major difference.
(4) Has the Company set up an internal standard to prohibit the insiders' use of private information to trade securities?	√		(4) The Company has established "Internal Procedures for Handling Serious Information", "Ethics and Business Practices" and "Standard of Ethical Conduct".	No major difference.

Evaluation Item	Implementation Status			Deviations from “the Corporate Governance Best-Practice Principles for TWSE/TPEX Listed Companies” and Reasons
	Yes	No	Abstract Illustration	
<p>3. The composition and duties of the Board of Directors</p> <p>(1) Has the Board of Directors formulated a diversified approach and specific management goals, and implemented them?</p>	√		<p>(1) Pursuant to Article 15 of the Company's 'Corporate Governance Best Practice Principles', members of the Board of Directors should consider that they possess the necessary knowledge, skills and qualities to perform the functions and consider the diversity of the functions.</p> <p>A. Among the five current members of the Board of Directors of the Company, there is one female member of the Board of Directors, and the ratio of females to all members of the Board of Directors is 20%, while that of males is 80%. The age range of all Board members is between 61 and 80 years old.</p> <p>B. Each of the Directors has a professional background, including business management, finance and accounting, commerce, information technology, etc. Among them, Ms. Hsu, Mei-Man has a background in accounting and financial analysis and is able to give professional advice to the Company from different perspectives. This is in accordance with the Company's policy of diversifying its board of directors , please refer to pages 8 to 9 of this annual report for the professional background and capabilities of each director.</p>	No major difference.
<p>(2) Has the Company set up other types of functional committees voluntarily in addition to the Remuneration Committee and Audit Committee in accordance with the law?</p>		√	<p>(2) The Company has established and is operating a Compensation Committee and an Audit Committee in accordance with the "Corporate Governance Practice Principles for TPEX Listed Companies"; and established Nominating, Corporate Governance and Sustainability Committee on December 19, 2024.</p>	No major difference.
<p>(3) Has the Company set up a performance appraisal method and assessment method for the Board of Directors, conducted an annual performance appraisal on a regular basis, submitted results of the performance assessments to the Board of Directors and used them as reference in determining compensation and nomination as well as additional term of office of individual Directors?</p>	√		<p>(3) The Company has established the "Board of Directors' Performance Evaluation Method", the scope of which may include the performance evaluation of the Board of Directors as a whole, individual board members, and functional committees; the evaluation may be conducted through internal self-evaluation by the Board of Directors, self-evaluation by board members (self or peer), peer evaluation, and evaluation by external professional organizations and experts; the performance evaluation of the Board of Directors The performance evaluation of the board of directors shall include at least the following five major aspects:</p> <p>1. Participation in the operation of the Company.</p>	No major difference.

Evaluation Item	Implementation Status			Deviations from “the Corporate Governance Best-Practice Principles for TWSE/TPEx Listed Companies” and Reasons
	Yes	No	Abstract Illustration	
(4) Does the Company regularly evaluate the independence of its certified public accountants?	√		<p>2.Improvement of the quality of the Board of Directors’ decision making.</p> <p>3.Composition and structure of the Board of Directors.</p> <p>4.Election and continuing education of directors.</p> <p>5.Internal Control.</p> <p>The internal performance of the entire Board of Directors is evaluated by the Company’s Corporate Governance unit after the end of the year, and the results are used as one of the references for the future selection or nomination of directors and the compensation of individual directors.</p> <p>The Board Performance Evaluation for 2025 was completed and reported by the Head of Corporate Governance in the Board Meeting on January 28, 2026. The result of evaluation for 2025 is 99 points.</p> <p>(4) The Audit Committee of the Company evaluates the independence and suitability of the accountants to whom it belongs annually, requests the accountants to provide the “Statement of Transcendent Independence” and the “Audit Quality Indicators (‘AQIs’)”, and evaluates base on the evaluation criteria and the AQIs as set out on pages 41 to 42 of this annual report. After confirming that the accountants have no financial interests or business relationships with the Company other than visa and tax fees, and that their family members do not violate the independence requirements, as well as referring to the information of the AQIs, we confirmed that the accountants and the firm are above the average level in audit experience and training hours. The most recent annual evaluation was discussed and approved by the Audit Committee on December 18, 2025, and proposed to the Board of Directors on December 18, 2025, which was resolved to approve the evaluation of the independence and suitability of the accountants.</p>	No major difference.
4. Does the TWSE/TPEx listed company have an adequate number of corporate governance personnel with appropriate qualifications, and appoint a chief corporate governance officer responsible for corporate governance-related matters (including but not limited to providing Directors and supervisors with required information to carry out their business, assisting Directors and supervisors with legal compliance, handling corporate registration and change of corporate registration-related	√		The Company has established a "Head of Corporate Governance" as the highest authority responsible for corporate governance-related matters in order to implement corporate governance and enhance the effectiveness of the Board of Directors. The "Head of Corporate Governance" as approved by the Board of Directors shall be the current Head of Accounting and Finance, Director Au, Keng-Hung,	No major difference.

Evaluation Item	Implementation Status			Deviations from “the Corporate Governance Best-Practice Principles for TWSE/TPEX Listed Companies” and Reasons
	Yes	No	Abstract Illustration	
matters, and preparing board and shareholders' meeting minutes)?			<p>who has been in charge of legal, financial, stock affairs or corporate governance related affairs units as defined in Article 21 for at least three years in a public company. He/she has also completed 12 hours of further training for the Head of Corporate Governance in 2025.</p> <p>The "Head of Corporate Governance" of the Company performs the following business highlights :</p> <ol style="list-style-type: none"> (1) Handling matters related to the meetings of the Board of Directors and shareholders' meetings in accordance with the law. (2) Prepare minutes of meetings of the Board of Directors and shareholders. (3) Provide the relevant legal regulations on corporate governance for board members and update them regularly. (4) Arrange education courses for board members. (5) Provide information required by the directors to carry out their business. (6) Assist directors in complying with the law. (7) Evaluate the purchase of directors' liability insurance. (8) Arrange communication meetings between the independent directors and the accountants or internal auditors. 	
5. Has the Company established a communication channel with interested parties (including but not limited to shareholders, employees, customers and suppliers), set up a page for these interested parties on the Company's website, and appropriately responded to them concerning important corporate social responsibility issues?	√		<ol style="list-style-type: none"> 1. The Company attaches importance to balancing the rights and obligations of stakeholders (including shareholders, investors, suppliers, customers, media, employees, government and competent authorities, non-profit entities, neighboring communities and others). The Company has set up a special area on its website for stakeholders and issues, and has appropriately responded to important CSR issues of concern to stakeholders, and has set up an electronic mailbox for stakeholder complaints, which is handled by dedicated personnel. 2. The Company's website has a special area for 'Corporate Governance' for investors to enquire and download the relevant rules and regulations on corporate governance, important matters resolved by the Board of Directors, and significant information. 	No major difference.
6. Has the Company appointed a professional stock transfer agent to handle shareholder-related affairs?	√		The Company always appoints a professional stock agent to handle the affairs of shareholders' meetings.	No major difference.
7. Information disclosure (1) Has the Company set up a website to disclose financial and corporate governance	√		(1) The Company established a public website to regularly disclose	No major difference.

Evaluation Item	Implementation Status			Deviations from “the Corporate Governance Best-Practice Principles for TWSE/TPEx Listed Companies” and Reasons
	Yes	No	Abstract Illustration	
<p>information?</p> <p>(2) Does the Company adopt other information disclosure methods (such as setting up an English website, appointing a dedicated person responsible for the collection and disclosure of company information, implementing the spokesman system, and posting the Company's corporate briefing process on the website, etc.)?</p> <p>(3) Has the Company publish and report annual financial report within two months after the end of a fiscal year, and publish and report financial reports for the first, second and third quarters as well as its operating status for each month before the specified deadline?</p>	√		<p>financial business information and corporate governance related information. There is also a special page for shareholders' service, which is regularly updated with financial and business information. For enquiry, please visit the Company's website (http://www.jem.com.tw).</p> <p>(2) The Company's website is available in both English and Chinese, and there is an investor area (corporate governance and shareholders' area) where financial and business information is regularly updated by dedicated staff. The Company has a spokesperson and a proxy spokesperson to regularly disclose the Company's information to the investing public on the Market Observation Post System (MOP) and the Company's website.</p> <p>(3) The Company currently reports its financial statements and monthly operations in accordance with the dates specified in the “List of over-the-counter matters to be handled”.</p>	<p>No major difference.</p> <p>No major difference.</p>
<p>8. Does the Company have any other important information (including but not limited to employee rights, employee care, investor relations, supplier relationship, rights and interests of interested parties, training for Directors and supervisors, implementation of risk management policies and risk measurement standards, implementation of customer policies, the Company's purchase of liability insurance for Directors and supervisors, etc.)?</p>	√		<p>(1) Employee rights and benefits: All employee rights and benefits, further education, training and retirement systems are clearly defined in the work rules and regulations, and the relevant provisions of the Labor Standards Law are implemented to protect employee rights and benefits and to stabilize employees' working and retirement lives.</p> <p>(2) Employee care: There are work rules for employees and the relevant regulations are actually enforced. The company has always valued the opinions of employees and encouraged employees to provide suggestions through quarterly labor-management meetings or informal communication channels at any time, and to use the two-way communication between employees and employers as a reference for improvement, so the interaction between employees and employers is good.</p> <p>(3) Investor Relations: The Company treats all shareholders fairly and openly. In terms of shareholders' meetings, the Company convenes annual shareholders' meetings in accordance with the Company Law and relevant laws and regulations, and establishes rules and regulations for shareholders' meetings in</p>	<p>No major difference.</p>

Evaluation Item	Implementation Status			Deviations from “the Corporate Governance Best-Practice Principles for TWSE/TPEx Listed Companies” and Reasons
	Yes	No	Abstract Illustration	
			<p>accordance with the law, properly maintains minutes of shareholders' meetings and fully discloses relevant information on the public observatory. In addition, the Company has a spokesperson and a proxy spokesperson to ensure that shareholders have the right to be fully informed of, participate in, and make decisions on major corporate issues, and to properly handle shareholder proposals, questions, and disputes.</p> <p>(4) Supplier relationship and stakeholder's rights: Uphold the principle of integrity, maintain good relationship and interaction with suppliers, no backlog or delay in payment, maintain good communication channels with stakeholders or financial institutions, etc., and contact the company at any time if there is a need.</p> <p>(5) Respect the rights of stakeholders: The Company's website (http://www.jem.com.tw) has an "Investor Relations" section to disclose information about the Company's finances and business. In addition, our stock agency, KGI's Stock Agency Department, also assists in handling questions and suggestions from shareholders and stakeholders of the Company. If legal issues are involved, we will appoint a lawyer to handle them in order to protect the interests of our stakeholders.</p> <p>(6) Directors and Supervisors of the Company for further education : A. The Company conducts regular financial, business and other related presentations for its directors and evaluates matters related to the future education of directors. B. The number of hours of continuing education for directors in the past year has been achieved.</p> <p>(7) The Company has established internal regulations in accordance with the law to serve as the basis for various risk management policies and risk measurement.</p> <p>(8) The company conducts regular business reviews with customers to understand their opinions on products and related issues to maintain a stable and good relationship in order to create company profits.</p> <p>(9) The Company has taken out a \$3 million directors' and supervisors' and managers' liability insurance policy with Shinkong Insurance Co.,</p>	

Evaluation Item	Implementation Status			Deviations from “the Corporate Governance Best-Practice Principles for TWSE/TPEx Listed Companies” and Reasons
	Yes	No	Abstract Illustration	
			Ltd. for the period from November 1, 2025 to November 1, 2026.	
<p>9. Please state the improvements made to the items in the corporate governance evaluation results issued by the Corporate Governance Center of the Taiwan Stock Exchange Co., Ltd., and indicate the enhancement and improvement measures for items not yet improved :</p> <p>The Company has been improving and enhancing its corporate governance operations to protect investors' rights and interests, and has made available on the Company's website for investors' reference information on the Company's profile, financial and business information, shareholders' meeting information, shareholder services, corporate governance and social responsibility and stakeholder-related information.</p>				

(4) Composition, Duties, and Operation of the Remuneration Committee :

1. Composition of the Remuneration Committee

April 30, 2026

Identity/Name		Qualifications	Professional Qualifications and Experience	Independence Status (Note)	Other Public Companies where the Individual Concurrently Serves as Member on Remuneration Committee
Independent Director	Chen, I-Hsun		1. Experience in remuneration committee, audit committee and board of directors. 2. Knowledge of industry and business. 3. Not having any of the circumstances described in Article 30 of the Company Act. 4. Please refer to "III, 2, (1) Directors and Supervisors" in this Annual Report of the Shareholders' Meeting for education experience.	(1)-(10)	0
Independent Director	Chuang, Te-Min		1. Experience in remuneration committee, audit committee and board of directors. 2. Knowledge of industry and business. 3. Not having any of the circumstances described in Article 30 of the Company Act. 4. Please refer to "III, 2, (1) Directors and Supervisors" in this Annual Report of the Shareholders' Meeting for education experience.	(1)-(10)	0
Independent Director	Hsu, Mei-Man		1. Knowledge of industry, business, and finance and accounting. 2. Not having any of the circumstances described in Article 30 of the Company Act. 3. Please refer to "III, 2, (1) Directors and Supervisors" in this Annual Report of the Shareholders' Meeting for education experience.	(1)-(10) 0	0

Note: The independence of each member in the last two years before and during their tenure of office. (Those who meet the criteria are disclosed in the above table)

- (1) A person who is not an employee of the Company or its affiliates.
- (2) A director or supervisor who is not a director or supervisor of the Company or its affiliates (except in the case where the Company and its parent company, subsidiary, or subsidiary of the same parent company serve concurrently as independent directors in accordance with the Act or local laws and regulations).
- (3) A natural person shareholder who does not hold more than 1% of the total issued shares of the Company or the top ten shares in the name of himself/herself, his/her spouse, minor children or others.
- (4) A person who is not a manager listed in (1) or a spouse, a relative within the second degree of consanguinity or a relative within the third degree of consanguinity of a person listed in (2) or (3).
- (5) A director, supervisor or employee of a corporate shareholder who does not directly hold more than 5% of the total number of issued shares of the Company, or who is one of the top five holders of shares, or who has designated a representative as a director or supervisor of the Company in accordance with Article 27(1) or (2) of the Company Act (except in the case where the independent directors of the Company and its parent company, subsidiary or subsidiary of the same parent company are concurrently appointed in accordance with this Act or the laws of the local country).
- (6) A director, supervisor or employee of another company who is not controlled by the same person as the company's directorship or more than half of the voting shares (except in the case of a concurrent appointment of independent directors of the company or its parent company, subsidiary or subsidiary of the same parent company under the Act or local laws and regulations).
- (7) A director (director), supervisor (supervisor), or employee of another company or organization who is not the same person or spouse of the chairman, president, or equivalent of the company (except in the case where the company and its parent company, subsidiary, or subsidiary of the same parent company serve concurrently as independent directors under this Act or the local laws and regulations).
- (8) Directors (directors), supervisors (supervisors), managers or shareholders holding more than 5% of the shares of a specific company or organization that does not have financial or business dealings with the Company (except that if the specific company or organization holds more than 20% but not more than 50% of the total issued shares of the Company and is an independent director of the Company and its parent company, a subsidiary or a subsidiary of the same parent company established in accordance with this Act or the laws of the local country that concurrently serve as independent directors (The Company shall not be limited to the following)
- (9) Professionals, sole proprietors, partners, directors (directors), supervisors (supervisors), managers and their spouses who do not provide audit or remuneration for the Company or its affiliates in the last two years in the amount of less than NT\$500,000 in aggregate for business, legal, financial, accounting and other related services. However, members of the Compensation Committee, the Public Takeover Review Committee, or the Special Committee on Mergers and Acquisitions who perform their duties and responsibilities in accordance with the Securities and Exchange Act or the relevant laws and regulations of the Business Mergers and Acquisitions Act shall be excluded.
- (10) The Company does not have one of the circumstances described in Article 30 of the Company Act.

2. Remuneration Committee Duties and Operations Information

- (1) There are three members of the Remuneration Committee of the Company.
- (2) Term of office: June 27, 2025 to May 28, 2028. The remuneration committee has held four (4)(A) meetings in the most recent year and the qualifications and attendance of the members are as follows :

Title	Name	Times of Attendance in Person(B)	Times of Attendance by Proxy	Attendance rate in person (%) (B/A)	Note
Convener	Shen, Hsiao-Ling	2	0	100%	Newly appointed on June 27, 2025
Member	Chen, I-Hsun	3	0	100%	Re-elected
Member	Chuang, Te-Min	3	0	100%	Re-elected
Convener	Shen, Hsiao-Ling	1	0	100%	Term expired on May 29, 2025

Other matters to be recorded:

1. Discussions and resolutions of the remuneration committee for the most recent year, and handling of members' opinions of the company :

Meeting Date of Remuneration Committee	Content of the motion	Resolution	The Company's handling of remuneration committee opinions
The 11 th meeting of the 5 st term May 08, 2025	1. Review of manager promotion cases.	Approved by all committee members.	Report to the Board of Directors, and approved by the chairman of the Board of Directors in consultation with all attending directors without objection.
The 1 st meeting of the 6 st term July 21, 2025	1. Remuneration of Independent Directors and Functional Committees.	Approved by all committee members.	Report to the Board of Directors, and approved by the chairman of the Board of Directors in consultation with all attending directors without objection.
The 2 nd meeting of the 6 st term December 18, 2025	1. Review of manager promotion cases. 2. Remuneration Committee work plan for 2026.	Approved by all committee members.	Report to the Board of Directors, and approved by the chairman of the Board of Directors in consultation with all attending directors without objection.

2. If the Board of Directors does not adopt or amend the recommendation of the Remuneration Committee, it shall state the date and period of the Board of Directors' meeting, the content of the resolution, the result of the Board of Directors' resolution and the Company's handling of the recommendation of the Remuneration Committee (if the remuneration approved by the Board of Directors is better than the recommendation of the Remuneration Committee, it shall state the difference and the reasons for the difference): None.
3. If a member of the Remuneration Committee has any objection or reservation to a resolution and it is recorded or stated in writing, the date and term of the Remuneration Committee, the content of the resolution, the opinions of all members and the treatment of the opinions of the members shall be stated: None.

(5) Nominating, Corporate Governance and Sustainability Committee Duties and Operations Information:

1. In order to improve the functions of the Board of Directors and strengthen the management mechanism, the Company established the Nominating, Corporate Governance and Sustainability Committee on December 19, 2024, which consists of 3 independent directors. Among them, Hsu, Mei-Man, as an independent director, has industry, business, and accounting knowledge, and Chen, I-Hsun and Chuang, Te-Min, as independent directors, have industry and business experience. Each of whom possesses the professional competence required by this committee.

2. Duties of Nominating, Corporate Governance and Sustainability Committee are as follows:

- (1) Select, screen, and recommend independent director candidates nominated by the Board of Directors for election at the Shareholders Meeting.
- (2) Assess and report to the Board of Directors on the independence of candidates in compliance with applicable regulations and the independence requirements of the competent authorities.
- (3) Continuously assess during their term as directors to ensure that the Board of Directors can bring in new perspectives, taking into account the deep understanding of the industry and the Company's operations of long-serving directors, which facilitates the better fulfillment of duties and the creation of value for shareholders. The term of independent directors is subject to the limitations imposed by the relevant regulations.
- (4) Establish a pool of potential independent director candidates for the Board of Directors.
- (5) Make recommendations to the Board of Directors on the size and composition of the Board of Directors and its committees.
- (6) Review shareholders' proposals related to nominations and corporate governance submitted at the Shareholders Meeting.
- (7) Revise the Company's "Corporate Governance Principles", review them periodically, and submit proposed changes to the Board of Directors.
- (8) Monitor the implementation of the "Corporate Governance Principles".
- (9) Review articles of committee, processes and membership and submit proposed changes to the Board of Directors.
- (10) Review the Company's policies and practices on sustainability, environmental, social and governance (ESG) and public issues involving investors and other key stakeholders.

3. Professional qualifications and experience of the members of the Nominating, Corporate Governance and Sustainability Committee, and their operations information:

- (1) There are three members of the Nominating, Corporate Governance and Sustainability Committee of the Company.
- (2) Term of office: June 27, 2025 to May 29, 2028. The Nominating, Corporate Governance and Sustainability Committee has held 1 (A) meeting in the most recent year and the professional qualifications, attendance, and the discussion are as follows:

Title	Name	Professional Qualifications and Experience	Times of Attendance in Person (B)	Times of Attendance by Proxy	Attendance in Person (%) (B/A)(Note)	Note
Convener	Hsu, Mei-Man	Please refer to pages 5 for information on directors and independent directors	2	0	100%	Newly appointed on June 27, 2025
Member	Chen, I-Hsun		3	0	100%	Re-elected
Member	Chuang, Te-Min		3	0	100%	Re-elected
Convener	Shen, Hsiao-Ling		1	0	100%	Term expired on May 29, 2025

Other matters to be recorded:

1. The date and period of the Nominating, Corporate Governance and Sustainability Committee's meeting, the content of the resolution, the advice or objection by the members of the Nominating Committee, the result of the Nominating Committees' resolution, and the Company's handling of the opinions of the Nominating Committee:

Meeting Date of Nominating Committee	Content of the resolution	Resolution	The Company's handling of nominating committee opinions
The 2 nd meeting of the 1st term March 10, 2025	1. Re-election of all the Company's Directors. 2. Nomination and consideration of candidates for Director/Independent Director. 3. Review the assurance organization for greenhouse gas inventory.	Approved by all committee members.	Report to the Board of Directors, and approved by the chairman of the Board of Directors in consultation with all attending directors without objection.
The 1 st meeting of the 2nd term July 21, 2025	1. Amendments to "Procedures for the Preparation and Assurance of the Sustainability Report."	Approved by all committee members.	Report to the Board of Directors, and approved by the chairman of the Board of Directors in consultation with all attending directors without objection.
The 2 nd meeting of the 2nd term August 7, 2025	1. Review of the 2024 "Sustainability Report".	Approved by all committee members.	Report to the Board of Directors, and approved by the chairman of the Board of Directors in consultation with all attending directors without objection.

(6) Implementation of the promotion of sustainable development and the differences and reasons for the rules of practice for sustainable development of TWSE/TPEX Listed Companies; Companies that meet certain criteria should disclose climate-related information :

1. Implementation of the promotion of sustainable development and the differences and reasons for the rules of practice for sustainable development of TWSE/TPEX Listed Companies"

Promoting items	Implementation Status			Deviations from the Sustainable Development Best Practice Principles for TWSE/TPEX Listed Companies and Reasons
	Yes	No	Abstract Illustrations	
1. Has the Company set up a sustainable development governance structure and a dedicated (or concurrent) sustainable development promotion unit which is authorized by the Board of Directors to be managed by high-level management and supervised by the Board of Directors?	√		(1) The Company established the "Nominating, Corporate Governance and Sustainability Committee" on December 19, 2024, with the Chief Financial Officer and Head of Corporate Governance as the chief convener, under the Board of Directors, and resolved to adopt a "Code of Practice for Sustainable Development" and report on its operations to the Board of Directors at least once a year. (2) The Company has set up a special unit for greenhouse gas inventory and verification schedule, hired experts to provide guidance. (3) The " Sustainable Development Best Practice Principles", "Code of Ethical Conduct" and "Code of Business Conduct with Integrity" are specified and required to be followed by the Company's Board of Directors, senior executives and Group staffs.	No major difference
2. Has the Company conducted risk evaluation for the environmental, social and corporate governance issues related to the operations of the Company based on the materiality principle, and formulated related risk management policies or strategies?	√		The Company has established a 'Sustainable Development Best Practice Principles' to evaluate the risk policy for implementing environmental, social and corporate governance issues related to the Company's operations. The Nomination, Corporate Governance, and Sustainability Committee, based on the principle of materiality and through communication with stakeholders, collects stakeholder concerns via questionnaires to assess material sustainability issues and their impact on the Company's sustainable development. The Committee also establishes risk management mechanisms and enhances the Company's response capabilities to implement enterprise-wide risk management and effectively reduce operational risks.	No major difference.

Promoting items	Implementation Status			Deviations from the Sustainable Development Best Practice Principles for TWSE/TPEX Listed Companies and Reasons																											
	Yes	No	Abstract Illustrations																												
<p>3. Environmental issues</p> <p>(1) Has the Company established an appropriate environmental management system according to its industrial characteristics?</p> <p>(2) Is the Company committed to improving the efficiency in the use of resources, and the use of recycled materials with low environmental impact?</p> <p>(3) Does the company evaluate the potential risks and opportunities of climate change for the business now and in the future, and take corresponding measures on climate related issues?</p> <p>(4) Has the Company calculated the greenhouse gas (GHG) emissions, water consumption and total weight of waste for the past two years, and formulated strategies for GHG emission reduction, water conservation and management of other forms of waste?</p>	<p>√</p> <p>√</p> <p>√</p> <p>√</p>		<p>(1) Our company complies with environmental regulations ROHS and REACH.</p> <p>(2) To fulfill the Company's commitment to energy conservation, carbon reduction, and environmental sustainability, the Company continues to improve electricity efficiency through traditional energy-saving measures, including replacing outdated high-energy-consuming equipment and optimizing lighting and air-conditioning systems, thereby gradually reducing electricity consumption and indirect carbon emissions. In addition, the company is also dedicated to improve the efficiency of resource utilization, such as using porcelain cups for drinking water, encouraging employees to bring their own tableware, and reusing envelopes and kraft paper bags. In order to avoid environmental pollution and waste of resources by discarding toner cartridges, the used toner cartridges of photocopiers and printers are collected and disposed of by the original manufacturer.</p> <p>(3) The company complies with the environmental protection regulations ROHS and REACH, and the procurement of various types of materials to the green energy as a priority, the central air-conditioning temperature regulation to save energy, lighting devices are also based on power-saving energy-saving devices to reduce the waste of energy.</p> <p>(4) Greenhouse gas emissions cover Taiwan, overseas plants and offices. Reasonable assurance information will be disclosed in the Sustainability Report. The greenhouse gas emissions for 2024 and 2025 are as follows:</p> <p style="text-align: center;">Unit: tCO2e/year</p> <table border="1" style="margin-left: auto; margin-right: auto;"> <thead> <tr> <th>Year \ Scope</th> <th>2024</th> <th>2025</th> </tr> </thead> <tbody> <tr> <td>Scope 1</td> <td>290.30</td> <td>471.59</td> </tr> <tr> <td>Scope 2</td> <td>5,657.30</td> <td>5,667.89</td> </tr> </tbody> </table> <p>Water consumption:</p> <table border="1" style="margin-left: auto; margin-right: auto;"> <thead> <tr> <th>Year</th> <th>2024</th> <th>2025</th> </tr> </thead> <tbody> <tr> <td>Water intake (million liters)</td> <td>0.665</td> <td>0.674</td> </tr> <tr> <td>Water discharge (million liters)</td> <td>0.665</td> <td>0.674</td> </tr> </tbody> </table> <p>Waste Statistics Table (Non-Hazardous Waste)</p> <table border="1" style="margin-left: auto; margin-right: auto;"> <thead> <tr> <th>Year</th> <th>2024</th> <th>2025</th> </tr> </thead> <tbody> <tr> <td>Waste generation (metric tons)</td> <td>15.49/year</td> <td>18.45/year</td> </tr> <tr> <td>Treatment method</td> <td>Incineration (including energy recovery)</td> <td>Incineration (including energy recovery)</td> </tr> </tbody> </table> <p>The Company continues to adopt "effective resource utilization" and "waste reduction" as its core strategies. In accordance with the Waste Disposal Act and relevant environmental regulations, waste is classified and managed systematically, while waste tracking and recycling processes are strengthened to ensure lawful disposal, controllable risks, improved recycling rates, and reduced environmental impact.</p>	Year \ Scope	2024	2025	Scope 1	290.30	471.59	Scope 2	5,657.30	5,667.89	Year	2024	2025	Water intake (million liters)	0.665	0.674	Water discharge (million liters)	0.665	0.674	Year	2024	2025	Waste generation (metric tons)	15.49/year	18.45/year	Treatment method	Incineration (including energy recovery)	Incineration (including energy recovery)	<p>(1) No major difference</p> <p>(2) No major difference</p> <p>(3) No major difference</p> <p>(4) No major difference</p>
Year \ Scope	2024	2025																													
Scope 1	290.30	471.59																													
Scope 2	5,657.30	5,667.89																													
Year	2024	2025																													
Water intake (million liters)	0.665	0.674																													
Water discharge (million liters)	0.665	0.674																													
Year	2024	2025																													
Waste generation (metric tons)	15.49/year	18.45/year																													
Treatment method	Incineration (including energy recovery)	Incineration (including energy recovery)																													
<p>4. Social issues</p> <p>(1) Has the Company formulated relevant management policies and procedures in accordance with relevant laws and regulations and international human rights conventions?</p>	<p>√</p>		<p>(1) In accordance with applicable labor laws and regulations, the Company provides labor insurance, health insurance, and pension contributions for employees to safeguard employee rights and interests. The Company also purchases other commercial insurance such as group accident insurance for all employees.</p>	<p>(1) No major difference</p>																											

Promoting items	Implementation Status			Deviations from the Sustainable Development Best Practice Principles for TWSE/TPEX Listed Companies and Reasons
	Yes	No	Abstract Illustrations	
(2) Does the Company formulate and implement reasonable policies of staff welfare (including compensation, vacation and other welfares), and reflect the operating performance or achievement in the compensation of the employees properly?	√		(2) The Company establishes reasonable compensation policies and employee welfare measures in accordance with the Labor Standards Law and with reference to industry salary levels and welfare practices.	(2) No major difference
(3) Does the Company provide a safe and healthy working environment for employees and regularly carry out safety and health education for employees?	√		(3) In 2025, we conducted approximately 40 hours of safety education courses for our employees, with a total of 40 attendances. The Company has entered into agreements with hospitals to provide annual routine health checks for employees and to review workplace safety conditions. All plant sites have successively completed ISO 45001 occupational health and safety certification. As of the end of March 2026, no occupational injuries or occupational disease incidents had occurred.	(3) No major difference
(4) Has the Company developed an effective training program for employees?	√		(4) The company provides relevant internal and external professional training to enrich employees' career skills.	(4) No major difference
(5) Did the Company follow relevant laws and international codes regarding product/service, customer health, safety, customer privacy, marketing and labeling, as well as formulate related policies to protect the rights and interests of consumers and develop a complaint-handling procedure?	√		(5) We comply with environmental standards and use ROHS compliant materials to maintain environmental hygiene.	(5) No major difference
(6) Did the Company formulate supplier management policies and require suppliers to follow relevant standards on environmental protection, occupational safety and health, or labor rights, as well as specify the implementation process?	√		(6) The company will conduct evaluation of new suppliers, and will strengthen the supplier's record of environmental and social impact in the future.	(6) No major difference
5. Did the Company follow internationally recognized guidelines in preparing and publishing reports; i.e., corporate social responsibility report to disclose non-financial information about the Company? Did the Company hire a third-party verification or assurance provider for such reports?		√	The Company prepares its Sustainability Report in accordance with the Global Reporting Initiative (GRI) Standards and with reference to the Sustainable Development Best Practice Principles for TWSE/TPEX Listed Companies. The report is publicly available for download on the Company's website and the Market Observation Post System (MOPS). Going forward, the Company will continue to advance sustainability assurance implementation in accordance with its established plans.	No major difference
6. Where the Company has established its own Sustainable Development Best Practice Principles in accordance with the "Sustainable Development Best Practice Principles for TWSE/TPEX Listed Companies," please describe any differences between the Company's operations and such principles: The Company amended its "Sustainable Development Best Practice Principles" on March 12, 2024, to further strengthen the implementation of corporate social responsibility.				
7. Other important information that may be useful in understanding the implementation of the promotion of sustainable development :				
<p>(1) Environmental protection: The Company is aware of the laws and regulations governing environmental protection, please refer to the information on environmental protection expenditures.</p> <p>(2) Human rights: Our employees are equal in employment opportunities regardless of gender, religion, or party affiliation, and the company creates a favorable working environment to ensure that employees are free from discrimination and harassment.</p> <p>(3) Safety and health: The Company's safety and health are controlled in accordance with governmental laws and regulations.</p> <p>(4) Social services: The Company participates in social services from time to time to enhance the Company's social participation, contribution and services, and actively participates in social emergency relief activities externally, for example:</p> <p>A. Donation to Taiwan Foundation for Children and Families, Keelung Branch Office in 2025.</p> <p>B. Donation for Thai Children's Day, Homemakers' Family Solidarity Day, refugee centers, Labor Day and flood disaster relief efforts in 2025.</p>				

2. Climate-related Information :

(1) Implementation of Climate-related Information

Items	Implementation Status
1. Describe the Board of Directors' and management's oversight and governance of climate-related risks and opportunities.	<p>The Board of Directors, as the highest governance unit for sustainability, has established a functional committee, the “Nominating, Corporate Governance and Sustainability Committee”, under the Board of Directors to assist the Board of Directors in its supervisory work and to report to the Board of Directors at least once a year.</p> <p>The focus is on regularly reviewing the Company's risks and opportunities associated with climate change.</p>
2. Describe how the identified climate risks and opportunities will affect the business, strategy, and finances of the Company (short, medium, and long term).	<p>1. Rising raw material costs. The impact on operations and finances is the higher production costs due to changes in input costs such as energy, water and output requirements (e.g., waste disposal).</p> <p>2. Strengthening the obligation to report emissions. The impact on operations and finances is increasing operating costs, such as the costs of GHG inventories and verification.</p>
3. Describe the financial impacts of extreme climate events and restructuring actions.	<p>1. In the annual financial planning, the Company allocates budgets for climate-related projects, including investments in energy-saving and carbon-reduction facilities (such as the installation of solar power generation equipment at the Thailand plant), in order to improve energy efficiency and carbon performance.</p> <p>2. When introducing new production lines, expanding production capacity, or adjusting regional deployment, the Company evaluates local climate risks, carbon footprints, and energy availability. The assessment results are incorporated into senior management and Board decision-making processes to ensure that investments align with the low-carbon transition strategy.</p> <p>3. The Company continues to strengthen its product strategy in response to climate change by introducing environmentally friendly materials, etc. to enhance market competitiveness.</p>
4. Describe how climate risk identification, assessment and management processes are integrated into the overall risk management system.	<p>To ensure timely responses to the impacts of climate change, the Company is gradually implementing a risk management framework covering supply chain management, operational sites, and regulatory compliance. The Nominating, Corporate Governance and Sustainability Committee will evaluate how</p>

	climate risk identification, assessment and management processes are integrated into the overall risk management system.
5. If scenario analysis is used to assess the resilience to climate change risk, the scenarios, parameters, assumptions, factors analyzed, and major financial impacts should be described.	Scenario analysis has not yet been used to assess the resilience to climate change risk.
6. If there is a transition plan for managing climate-related risks, describe the content of the plan, as well as the indicators and objectives used to identify and manage physical and transition risks.	There is currently no transition plan to manage climate-related risks.
7. If internal carbon pricing is used as a planning tool, the basis for price setting should be specified.	There is currently no planning tool for carbon pricing.
8. If climate-related targets are set, information on the activities covered, the scope of greenhouse gas emissions, the planning period, and the annual progress of achievement should be stated; if carbon credits or renewable energy certificates (RECs) are used to achieve the relevant targets, the source and amount of carbon reduction credits or renewable energy certificates (RECs) should be stated.	There is currently no climate-related targets have been set.
9. Greenhouse gas inventory and assurance, and reduction targets, strategies and specific action plans.	Please refer to “(2) Company's Greenhouse Gas Inventory and Assurance for the Last Two Years”.

(2) Company's Greenhouse Gas Inventory and Assurance for the Last Two Years

A. Greenhouse Gas Inventory Information

Describe the GHG emissions (metric tons of CO ₂ e), intensity (metric tons of CO ₂ e/million), and the scope of the data for the last two years.		
Year	2024 (metric tons of CO ₂ e)	2025 (metric tons of CO ₂ e)
Scope (Category) 1	290.30	471.59
Scope (Category) 2	5,657.30	5,667.89
Total	5,947.60	6,133.48

B. Greenhouse Gas Assurance Information

Describe the assurance status for the last two years ended on the date of printing of the annual report, including the assurance scope, organization, criteria, and opinion.
Assurance scope: Scope (Category) 1, Scope (Category) 2 Assurance organization: Grant Thornton Taiwan Assurance criteria: ISO 14064-1:2018 Assurance opinion: Based on the procedures performed and the evidence obtained, Jinsonn Electronics is in compliance with ISO 14064-1:2018 in preparing the GHG Statement for the period of January 1, 2023, to December 31, 2024, in all material respects as set forth in the first paragraph.

C. Greenhouse Gas Reduction Targets, Strategies and Specific Action Plans

Describe the base year of GHG reduction and its data, reduction targets, strategies and specific action plans and achievement of reduction targets.
The Company has obtained third-party verification of the ISO 14064-1:2018 energy management system and will conduct a greenhouse gas inventory to track the effectiveness of emission reductions in accordance with requirements using 2024 as the base year.

(7) Implementation Status of Ethical Corporate Management and Deviations from the Ethical Corporate Management Best Practice Principles for TWSE/TPEX Listed Companies and Reasons :

Evaluation Item	Implementation Status			Deviations from the Ethical Corporate Management Best Practice Principles for TWSE/TPEX Listed Companies and Reasons
	Yes	No	Abstract Illustrations	
1. Setting business Ethical Corporate Management policies and programs (1) Does the Company develop business integrity policies to be passed by the Board, and express its commitment to the policies and practices of Ethical Corporate Management in its regulations and in the external documents, and do the Board of Directors and the management actively implement the business policies?	√		(1) In addition to the Company's ethical management principles and the sound development of its corporate culture, the Company has formulated the 'Ethical Corporate Management Best Practice Principles', the 'Code of Ethical Conduct' and the 'Work Rules' and other related procedures and penalties to be submitted to the Board of Directors and the Shareholders' Meeting for approval, so as to regulate the employees and to ensure that all staff members of the Company are honest in their dealings with each other and that they do not use improper methods (e.g., theft, fraud, coercion and bribery, etc.) in order to try to benefit the Company or individuals.	(1) No major difference
(2) Has the Company establish a risk assessment mechanism against unethical conduct, analyze and assess on a regular basis business activities within their business scope which are at a higher risk of being involved in unethical conduct, and establish prevention programs accordingly adopted precautionary measures in respect of business activities with a high risk of dishonesty and at least include preventive measure in Article 7 (2) of the Ethical Corporate Management Best Practice Principles for TWSE/TPEX Listed Companies?	√		(2) The Company's "Ethical Management and Guideline" and "Corporate Governance Principles" have stated the prevention measures for unethical conduct.	(2) No major difference.
(3) Has the Company set up a program for the prevention of dishonesty as well as the procedures, conduct guidelines and a disciplinary and appeals system in various programs and implemented them?	√		(3) The Company implemented internal and external training on ethical management education and training for approximately 632.5 hours, with a total of 259 participants in 2025.	(3) No major difference.

Evaluation Item	Implementation Status			Deviations from the Ethical Corporate Management Best Practice Principles for TWSE/TPEx Listed Companies and Reasons
	Yes	No	Abstract Illustrations	
			The Company has established a "Ethical Management and Guidelines" to regulate business activities with higher risk of unethical business practices, such as prevention of bribery, bribery acceptance and illegal political contributions.	
<p>2. Implementation of Ethical Corporate Management</p> <p>(1) Does the Company assess the integrity record of its business partner, and stipulate the terms of conduct on integrity in the contract with the business partner?</p> <p>(2) Has the Company set up a dedicated (or concurrent) corporate integrity promotion unit under the Board of Directors which report to the Board of Directors on a regular basis (at least once a year) on supervising the implementation of the ethical corporate management policies and prevention programs?</p> <p>(3) Has the Company formulated policies to prevent conflicts of interest, provided appropriate channels for statements and implemented them?</p>	<p>√</p> <p>√</p> <p>√</p>		<p>(1) The Company's ' Ethical Corporate Management Best Practice Principles' and 'Corporate Governance Best Practice Principle' already contained a program for preventing dishonest behavior.</p> <p>(2) The Company has established the 'Nominating, Corporate Governance and Sustainability Committee' on December 19, 2024, which is responsible for formulating and supervising the implementation of ethical management policies and preventive programmes to ensure their implementation, and this committee will report to the Board of Directors on 28 January 2026 on its implementation status.</p> <p>The Company has implemented the integrity management policy and the related implementation status in 2025:</p> <p>A. The Company has stipulated in the 'Work Rules' and the 'Integrity and Intellectual Property Rights Agreement', 'Integrity and Confidentiality Agreement', 'Competition Terms and Confidentiality Agreement' and 'Confidentiality of Material Internal Information Agreement' signed by all employees that all employees must be honest and fair in the execution of their duties and comply with governmental laws and regulations. The Board of Directors and management are also committed to actively implementing the business philosophy of integrity.</p> <p>B. Education and training: The dedicated unit arranges internal education and training on integrity management, with a total of 424 hours of education and training in 2025.</p> <p>(3) The Company's 'Ethical Corporate Management Best Practice Principles' provides for a system of avoidance of directors' interests. When there is a conflict of interest in a board of directors' meeting, the principle of avoidance of interest will be followed; The Company has set up an internal 'Employee Opinion Box' to encourage employees to express their opinions and complaints about violations of the law to the relevant supervisors directly or to the Company's presidential office in person; The Company has also</p>	<p>(1) No major difference.</p> <p>(2) No major difference.</p> <p>(3) No major difference.</p>

Evaluation Item	Implementation Status			Deviations from the Ethical Corporate Management Best Practice Principles for TWSE/TPEX Listed Companies and Reasons
	Yes	No	Abstract Illustrations	
(4) Has the Company established an effective accounting system and internal control system for the implementation of ethical corporate management, which is checked by the internal auditing unit based on the results of assessment of the risk of involvement in unethical conduct, devise relevant audit plans and examine accordingly the compliance with the prevention programs or engage audited by external auditors?	√		established the 'Regulations for Reporting Fraudulent Behaviour' for reporting conflict of interest incidents. (4) To ensure the implementation of integrity management, the Company has established an effective internal control and accounting system, which is effectively implemented. The auditors of the Audit Office conduct regular and irregular audits and report the audit reports to the Audit Committee and the Board of Directors.	(4) No major difference.
(5) Does the Company hold regular internal and external training on business integrity?	√		(5) The management team of the Company promotes the rules and concepts of integrity management at monthly meetings or departmental meetings.	(5) No major difference.
3. Implementing the whistle-blowing system				
(1) Does the Company formulate a concrete whistle-blowing and reward system, build convenient grievance channels, and assign the appropriate personnel to investigate the reported parties?	√		(1) The Company has established the 'Work Rules' and Article 23 of the 'Ethical Corporate Management Best Practice Principles' as the relevant regulations for the whistle-blowing system. Employees who violate the regulations will be punished according to the severity of the offence. The Company has also set up an 'Employee Opinion Box' to encourage employees to express their opinions and complaints about violations of the law to the relevant supervisors directly or to the Company's presidential office to present the contents of the report in person.	(1) No major difference.
(2) Does the Company establish standard operating procedures for the investigation on complaints and the follow-up measures to be adopted after the investigation is completed as well as the relevant confidentiality mechanisms?	√		(2) The Company has set up the 'Employee Opinion Box' whistle-blowing system on the Company's official website and internally to receive reports of any unlawful or unethical matters, which will be investigated by an independent specialised unit and the identity of the informant and the content of the report will be kept confidential.	(2) No major difference.
(3) Does the Company take measures to protect whistle-blowers from inappropriate disciplinary actions?	√		(3) The Company has also established the 'Regulations Governing the Reporting of Fraudulent Acts', under which the Company will protect the identity of any informant who reports any violation of the Code of Ethics or any fraudulent act, as well as any employee or any person who participates in the process of investigation, and will protect him/her from any improper handling or unfair retaliation or treatment.	(3) No major difference.
4. Enhancing disclosure of information Does the Company disclose the content and performance of the Ethical Corporate Management Best Practice Principles on the Company website and Market Observation Post System?	√		The Company discloses the ethical management of the Company in its annual report, which has been uploaded to the Market Observation Post System.	No major difference.
5. If the Company has its own code of conduct on integrity management based on the 'Ethical Corporate Management Best Practice Principles for TWSE/TPEX Listed Companies', please describe the differences between its operation and the code: Currently, the Company has formulated the 'Ethical Corporate Management Best Practice Principles', which covers the purpose, scope, compliance with laws and regulations, prohibited matters, reporting system, avoidance of interests, and disclosure of information, etc., and clearly defines the requirements for integrity management, which is not significantly different from the 'Ethical Corporate Management Best Practice Principles for TWSE/TPEX Listed Companies'. It is not significantly different from the 'Ethical Corporate Management Best Practice Principles' and meets the requirements of the Code of Practice on Corporate Social Responsibility for TWSE/TPEX Listed Companies.				

Evaluation Item	Implementation Status			Deviations from the Ethical Corporate Management Best Practice Principles for TWSE/TPEX Listed Companies and Reasons
	Yes	No	Abstract Illustrations	
6. Other important information that will help to understand the operation of the Company's integrity :				
(1) The Company has established the 'Code of Corporate Governance', which is implemented by the Board of Directors and the management in addition to the internal issuance for the purpose of corporate governance compliance, and has been placed on the Company's website (http://www.jem.com.tw) in the investor section for shareholders, investors, and stakeholders to make inquiries.				
(2) In order to prevent insider trading, the Board of Directors of the Company adopted the 'Procedures for Handling of Material Internal Information and Prevention of Insider Trading' on August 5, 2022 and asked each elected director to sign a confidentiality undertaking; the employees of the Company signed the 'Agreement on Integrity, Confidentiality and Intellectual Property', 'Integrity and Confidentiality Undertaking', 'Non-Corruption Confidentiality Undertaking', 'Competitive Clauses/Non-Disclosure Agreement', 'Confidentiality Undertaking of Material Internal Information', etc related confidentiality agreements when they are on board.				

(8) Other important information to enhance understanding of the operation of corporate governance:

1. The "Procedures for Handling Material Internal Information" established for the management of material internal information of the Company have been communicated to all directors, supervisors, managers and employees. The procedures and precautions are posted on the Company's intranet for all employees to follow in order to avoid violations or insider trading.
2. The Company distributes the latest version of the "Rules and Regulations Concerning the Shareholding of Insiders in Over-the-Counter and Emerging Companies" prepared by the Securities and Exchange Commission to insiders upon their appointment as directors, supervisors, managers and other insiders of the Company, so that they can follow them. The Company also provides directors and supervisors with information on relevant laws and regulations that they should be aware of at all times.
3. The accounting officer of the Company has passed the professional certification of accounting officer by the Accounting Research and Development Foundation.
4. The Company's website: <http://www.jem.com.tw> Investment Relationship Zone.

(9) Implementation of the internal control system :

1. Statement of Internal Control System

Joinsoon Electronics Mfg. Co., Ltd.
Statement of Internal Control System

Date : March 10, 2026

Based on the results of self-evaluation on the internal control system of the company in 2025, we hereby declare as follows: :

- I. The Company acknowledges that the implementation and maintenance of internal control system is the responsibility of Board of Directors and managers, and the Company has established such system. The internal capital system is aimed to reasonably assure that the goals such as the effectiveness and the efficiency of operations (including profitability, performance and protection of assets), the reliability of financial reporting and the compliance of applicable law and regulations are achieved.
- II. The internal control system has its innate restriction. An effective internal control system can only ensure the foregoing three goals are achieved; nevertheless, due to the change of environment and conditions, the effectiveness of internal control system will be changed accordingly. However, the internal control system of the Company has self-monitoring function and the Company will take corrective action once any defect is identified.
- III. The Company determines the effectiveness of the design and implementation of its internal control system in accordance with the items in “Governing Regulations for Public Company’s Establishment of Internal Control System” (hereinafter referred to as “Governing Regulations”) that are related to the effectiveness of internal control systems. The items adopted in the “Governing Regulations” for determining the internal control system are the five constitutional elements of the internal control system divided according to the management and control process: 1. control environment, 2. risk assessment, 3. control process, 4. information and communication, and 5. supervision. Each element further encompasses several items. Please refer to “Governing Regulations” for details.
- IV. The Company has adopted the above-mentioned determining items and conducted inspection of the design and effectiveness of its internal control system.
- V. Based on results of the above evaluation, the Company believes that the internal control system (including the supervision and management of subsidiaries) in Note 2 of December 31st, 2025 including understanding the effect of operation, the extent to which the efficiency objectives have been achieved and reporting, is reliable, timely and transparent. The design and execution complying with relevant norms, decrees and regulations and following the relevant internal control system are effective and can reasonably ensure the achievement of the above objectives.
- VI. This statement will be the main content of the annual report and the public instructions of the Company and made public to the outside world. If the above disclosure has anything false or concealed, it will involve the legal liability of Article 20, Article 32, Article 171 and Article 174 of the Securities and Exchange Act.
- VII. This statement has been approved by the Board of Directors on March 10, 2026. Among the seven directors, none of them has any objection and agreed to the content of this declaration. The rest of them agree with the content of this statement and make this statement.

Joinsoon Electronics Mfg. Co., Ltd
Chairman : Huang, Chin-Hsiung
General Manager : Huang, Chin-Chi

2. If accountants are entrusted to examine the internal control system on a project basis, the auditing report of accountants should be disclosed: None.

(10) Important resolutions of the shareholders' meeting and the Board of Directors in the most recent year and up to the date of publication of the annual report :

1. Important Resolutions for the 2025 Annual General Meeting of Shareholders

Meeting Date	Important Resolutions	Implementation Status
May 29, 2025	1. Business Report and Financial Report for FY 2024.	Resolution approved.
	2. The loss appropriation proposal for FY 2024.	Resolution approved.
	3. Amendment to some provisions of the "Articles of Incorporation".	Approved for registration on July 21, 2025 by the Ministry of Economic Affairs.
	4. Proposal to lift the non-compete restrictions on the 17th directors	Resolution approved.

2. Important resolutions of the Board of Directors for FY 2025 and up to the date of publication of the Annual Report

Meeting Date	Summary of Important Resolutions
March 10, 2025	1. Approved the Individual and Consolidated Financial Reports for FY 2024.
	2. Approved the Business Report for FY 2024.
	3. Approved the 2024 loss appropriation.
	4. Approved the amendments to partial articles of the "Regulations Governing the Remuneration Regulations."
	5. Approved the amendments to partial articles of the Articles of Incorporation.
	6. Approved to re-elect all the Company's Directors .
	7. Approved the nomination and consideration of the 2025 General Meeting of Shareholders as chosen by the Board of Directors .
	8. Approved the date, place, and agenda for the Company's 2025 Annual General Shareholders' Meeting as determined by the Board of Directors.
	9. Approved to provide endorsement and guarantee for the financing from Land And House Bank Plc for the total credit line of Baht 50 million for the Company's 100% Thai subsidiary, Joinson Electronics Manufacturing Co., Ltd..
	10. Approved the "Statement on Internal Control System" for FY 2024.
	11. Approved the assurance organization for greenhouse gas inventory.
	12. Approved the application for a short-term line of credit from a financial organization.
May 8, 2025	1. Approved the consolidated financial statements for the 1st quarter of 2025 .
	2. Approved the promotion of managerial officers .
	3. Approved 2024 Employee stock options in capital increase - Situation where the manager may subscribe.
May 29, 2025	1. Approved the election of the Chairperson and Vice Chairperson of the 17th Board of Directors .
June 27, 2025	1. Approved to appointment of members of the 6th Compensation Committee. .
	2. Approved the appointment of members of the 2nd Nomination, Corporate Governance and Sustainability Committee .

	3. Approved the renewal of short-term line of credit from a financial institution.
July 21, 2025	1. Approved the adoption of the “Procedures for Preparation and Assurance of Sustainability Reports.”.
	2. Approved the remuneration proposal for independent directors and functional committees.
August 7, 2024	1. Approved the consolidated financial statements for the 2nd quarter of 2025.
	2. Approved the Sustainability Report.
	3. Approved the amendments to partial articles of the “Procedures for Handling Material Inside Information.”
	4. Approved the renewal of short-term line of credit from a financial institution.
	8. Approved the renewal of a short-term line of credit from a financial organization.
November 19, 2025	1. Approved the consolidated financial statements for the 3rd quarter of 2025.
	2. Approved to provide a loan of US\$5,000,000 to the Company's subsidiary, Joinsoon Electronics Manufacturing Co., Ltd.
	3. Approved the directors’ (including officers’) liability insurance plan.
December 18, 2025	1. Approved the 2026 Business Plan and Budget.
	2. Approved the independence and qualifications of the CPAs engaged for the audit of the financial statements.
	3. Approved the public accountant's fee for the year of 2025.
	4. Approved the audit plan for 2026.
	5. Approved amendments to the “Rules of Procedure for Board of Directors Meetings.”
	6. Approved the issuance of new common shares through a 2025 cash capital increase.
	7. Approved the renewal of a short-term line of credit from a financial organization.
	8. Approved the promotion of managerial officers.
	9. Approved remuneration committee’s 2025 work plan.
January 28, 2026	1. Approved the 2026 annual plan of the Nomination, Corporate Governance and Sustainability Committee.
	2. Approved the 2025 annual bonuses and compensation for managerial officers.
	3. Approved the subscription allocation for managerial officers under the employee stock subscription plan for the 2025 cash capital increase.
March 10, 2026	1. Approved the Individual Financial Report and the Consolidated Financial Report for FY 2025.
	2. Approved the business report for FY 2025.
	3. Approved the 2025 loss appropriation.
	4. Approved the date, place and agenda of the 2026 General Meeting of Shareholders as chosen by the Board of Directors.
	5. Approved to provide endorsement and guarantee for the financing for the Company's 100% Thai subsidiary, Joinsoon Electronics Manufacturing Co., Ltd and its 100% directly or indirectly subsidiaries, Suzhou Jian-Ho Precision Electronics Co., Ltd. and Dongguan Jian-Wei Electronics Products Co., Ltd..
	6. Approved the ‘Statement of Internal Control System’ for FY 2025.
	7. Approved the amendments to the “General Principles of the Non-Assurance Services Policy.”
	8. Approved the application for a short-term line of credit from a financial organization.

(11) Directors who have dissenting opinions on important resolutions passed by the board <https://www.phihong.com.tw/download/1653070796.pdf> of directors as of the publication date of the most recent annual report and have recorded or stated in writing the main content: None.

4. Information on CPA Professional Fees

- (1) The amount of audit fees and non-audit fees paid to the CPA, his firm and affiliates, and the content of non-audit services should be disclosed:

Unit: NT\$ thousand

Accounting Firm	Name of CPA	Period of Audit	Audit Fees	Non-audit Fees	Total	Note
KPMG	Au, Yao-Chun	January 1, 2025~ December 31, 2025	4,537	624	5,161	
KPMG	Wang, I-Wen					

- (2) If the accounting firm is changed and the audit fee paid in the year of change is lower than the audit fee of the year before the change, the amount of the audit fee before and after the change and the reasons shall be disclosed: None.
- (3) If the audit fee decreases by 10% or more from the previous year, the amount, percentage and reason of the decrease should be disclosed: There is no situation where the audit fee decreases by 15% or more from the previous year.
- (4) The term "audit fee" currently refers to the fee paid by the Company to a CPA in connection with the audit, review and examination of financial reports and the review of financial forecasts.

5. The Company has changed its accountant information in the recent two years and subsequent periods:
None

6. Independent Evaluation of Accountants

The Company's management periodically evaluates the independence of the CPA on an annual basis through the following evaluations, and the evaluated accountants in 2024 are independent:

Items	Result
1. There has not been a seven-year non-replacement as of the most recent issue of the certification.	Yes
2. There is no material financial interest with the principals.	Yes
3. Avoid any inappropriate relationship with the principal.	Yes
4. Accountants should ensure the integrity, impartiality and independence of their assistants.	Yes
5. The financial statements of the service provider within two years prior to the commencement of business shall not be subject to audit.	Yes
6. The name of the accountant shall not be used for others.	Yes
7. The Company and its affiliates do not hold shares in the Company.	Yes
8. The Company and its affiliates do not have any monetary borrowings with the Company.	Yes
9. The Company has no joint investment or benefit-sharing relationship with the Company or its affiliates.	Yes
10. The Company or its affiliates do not have a regular job and receive a fixed salary.	Yes
11. Not involved in the management functions of the Company or its affiliates in making decisions.	Yes
12. No other business in which the Company may lose its independence.	Yes
13. Not related to the Company's management by spouse, consanguinity or consanguinity within the first degree of consanguinity or second degree of consanguinity.	Yes
14. No commission is received in connection with the business.	Yes
15. No disciplinary action has been taken against the Company or the principle of independence has been compromised to date.	Yes

(2) The five structures of AQI information, and the 13 indicators, are summarised below :

Structures	Indicators
Professionalism	Audit experience, training hours, turnover rate, professional support
Quality Control	Accountant load, audit input, case quality review (EQCR) review status, quality familiarity
Independence	Percentage of non-audit service fees, customer familiarity
Supervision	External inspection deficiencies and penalties, letters of improvement from competent authorities
Innovation	Innovative Planning or Creativity

7. Chairman, General Manager, or Any Managerial Officer in Charge of Financial or Accounting Matters in the Most Recent Fiscal Year Holding a Position at the CPAs' Accounting Firm or at an Affiliate of Such Accounting Firm: None.

8. Changes in the shareholding of directors, managers and shareholders holding more than 10% of the shares as well as changes in shareholding pledges for the most recent year ended on the date of publication of the annual report :

(1) Changes in Shareholding :

Unit: Share

Title	Name	FY 2025		As of April 14, 2026	
		Increase (decrease) in number of shares held	Increase (decrease) in number of pledged shares held	Increase (decrease) in number of shares held	Increase (decrease) in number of pledged shares held
Chairman and Plant Manager (Thailand plant)	Huang, Chin-Hsiung	—	—	707,485	—
Vice President and General Manager	Huang, Chin-Chi	—	—	571,249	—
Independent Director (Note 1)	Hsu, Mei-Man	—	—	—	—
Independent Director	Chuang, Te-Min	—	—	—	—
General Manager of Business Group	Lin, Wu-Chi	—	—	—	—
Vice President	Lo, Jung-Tsang	—	—	—	—
Vice President	Hsieh, Pei-Fei	—	—	—	—
Vice President (Note 2)	Ou, Keng-Hung	—	—	12,000	—
Associate (Note 3)	Peng, Yu-Wei	—	—	200,000	—
Associate	Kuo, Shuan-Hsu	—	—	46,636	—
Associate	Hsieh, Hui-Chun	—	—	—	—
Associate	Chiu, Ching-Min	—	—	—	—
Associate	Lin, Ching-Hung	—	—	10,000	—
Associate	Hsieh, Wei-Hua	—	—	—	—
Associate (Note 4)	Liang, Zheng-Yin	—	—	2,000	—

Note 1: Independent Director Hsu, Mei-Man is elected on May 29, 2025.

Note 2: Mr. Ou, Keng-Hung, Vice President of the General Administration Division, also holds the positions of Treasurer, Accounting Supervisor, Chief Information Officer and Corporate Governance Supervisor.

Note 3: Mr. Peng, Yu-Wei has changed his position as Vice President on June 1, 2025.

Note 4: Mr. Liang, Zheng-Yin was promoted to Associate on 1 January 2026.

(2) If the relative party to the transfer of the equity interest is a related party: None.

(3) If the relative party to the pledge of equity is a related party: None.

9. Information on the top ten shareholders who are related to each other or are spouses or second-degree relatives :

April 14, 2026 ; Unit : Share

Name	Shares held by the person		Shares held by spouse, minor children		Total shares held in others' names		Names and relationships of the top ten shareholders who are related to other top-ten shareholders or are their spouses or second-degree relatives		Note
	Number of shares	Shareholding percentage (%)	Number of shares	Shareholding percentage (%)	Number of shares	Shareholding percentage (%)	Name	Relationship	
Lin, Chen-Yang	7,035,170	5.11	—	—	—	—	None	None	—
Digiland Investment Inc.	6,862,457	4.99	—	—	—	—	None	None	—
Digiland Investment Inc. People in charge : Huang, Chin-Chi	5,028,465	3.65	—	—	—	—	Huang, Chin-Hsiung	Second degree	—
							Yongsheng Investment Inc.	The person in charge of the Yongsheng investment Inc. is 1st degree relative.	—
Huang, Chin-Hsiung	6,751,268	4.69	1,717	0.00	—	—	Huang, Chin-Chi	Second degree	—
Huang, Chin-Chi	5,028,465	3.65	—	—	—	—	Huang, Chin-Hsiung	Second degree	—
							Yongsheng Investment Inc.	The person in charge of the Yongsheng investment Inc. is 1st degree relative.	—
Li, Yeh-Hsu	3,810,526	2.77	—	—	—	—	None	None	—
GB Investment Co., Ltd.	3,306,105	2.40	—	—	—	—	None	None	—
GB Investment Co., Ltd. Person in charge : Chiu, Li-Yueh	130,745	0.10	90,590	0.07	—	—	None	None	—
Lin, Chao-Mao	2,496,000	1.81	—	—	—	—	None	None	—
Zeng, Yi-Chun	2,480,000	1.80	—	—	—	—	None	None	—
Yongsheng Investment Inc.	2,344,574	1.70	—	—	—	—	None	None	—
Yongsheng Investment Inc. Person in charge : Huang, Chien-Ta	198,469	0.14	—	—	—	—	Huang, Chin-Chi	1st degree	—
Chen, Hung-Ta	1,319,930	0.96	—	—	—	—	None	None	—

10.Total Numbers and Equity of Shares Held In any Single Enterprise by the Company, Directors, Supervisors, Managers and Any Companies Controlled Either Directly or Indirectly by the Company: :

March 31, 2026 ; Unit: Thousand shares; %

Reinvested businesses (Note)	Investment by the Company		Investments directly or indirectly controlled by directors, supervisors and managers		Total investment	
	Number of shares	Shareholding ratio	Number of shares	Shareholding ratio	Number of shares	Shareholding ratio
Conquest International Holding Corporation (BVI)	10,128	100%	-	-	10,128	100%
Evergrand Holdings Limited	3,000	100%	-	-	3,000	100%
Joinsoon Electronics Manufacturing (Thailand) Co., Ltd.	10,826	100%			10,826	100%
Teamplus Technology Inc.	2,385	14.63%	-	-	2,385	14.63%

Note: Based on the Company's long-term equity investments under the equity method.

IV. Information on Capital Raising Activities

1. Capital and Shares

(1) Source of Capital

1. Formation of Capital

Unit : NT\$ Thousand/Thousand Shares

Month / Year	Par Value	Authorized Capital		Paid-in Capital		Remarks		
		Number of shares	Amount	Number of shares	Amount	Source of Capital	Use of property other than cash to offset payment for shares	Others
July 1998	1,000	108.5	108,500	108.5	108,500	Cash capital increase by NT\$ 33,500 thousand	-	Ching (087) Shou Shang Tze No. 087122092 issued on August 3, 1998
January 2000	1,000	170	170,000	170	170,000	Cash capital increase by NT\$ 61,500 thousand	-	Ching Shang Tze No. 089104670 issued on February 19, 2000
December 2001	10	45,000	450,000	28,700	287,000	Cash capital increase by NT\$ 70,000 thousand Capital increase by NT\$47,000 thousand through earnings	-	Ching Shou Shang Tze No. 09101012010 issued on January 15, 2002
December 2002	10	45,000	450,000	33,005	330,050	Capital increase by NT\$43,050 thousand through earnings	-	Ching Shou Shang Tze No. 09101524070 issued on January 13, 2003
September 2003 (Note 1)	10	45,000	450,000	35,000	350,000	Capital increase by NT\$19,950 thousand through earnings	-	Tai-Cai-Zheng-Yi-Zi No. 0920137523 issued on August 25, 2003
September 2004	10	45,000	450,000	40,000	400,000	Capital increase by NT\$50,000 thousand through earnings	-	Jin-Guang-Zheng-Yi-Zi No. 0930137459 issued on August 23, 2004
September 2004	21	45,000	450,000	41,200	412,000	Cash capital increase by NT\$ 33,500 thousand	-	Jin-Guang-Zheng-Yi-Zi No. 0930138041 issued on August 30, 2004
August 2006	10	80,000	800,000	43,600	436,000	Capital increase by NT\$24,000 thousand through earnings	-	Jin-Guang-Zheng-Yi-Zi No. 0950135450 issued on August 10, 2006
June 2007	26	80,000	800,000	47,600	476,000	Cash capital increase by NT\$ 40,000 thousand	-	Jin-Guang-Zheng-Yi-Zi No. 0960028162 issued on June 5, 2007
September 2007	10	80,000	800,000	50,280	502,800	Capital increase by NT\$26,800 thousand through earnings	-	Jin-Guang-Zheng-Yi-Zi No. 0960045248 issued on August 22, 2007
January 2008	26	80,000	800,000	54,280	542,800	Cash capital increase by NT\$ 40,000 thousand	-	Jin-Guang-Zheng-Yi-Zi No. 096075434 issued on January 10, 2008
August 2008	10	80,000	800,000	64,311	643,107	Cash capital increase by NT\$ 75,881 thousand Capital reserve increased by NT\$24,426 thousand	-	Jin-Guang-Zheng-Yi-Zi No. 0970041566 issued August 15, 2008
May 2009	12	80,000	800,000	72,350	723,497	Cash capital increase by NT\$ 80,390 thousand	-	Jin-Guang-Zheng-Yi-Zi No. 0980016644 issued April 22, 2009
March 2010	20	150,000	1,500,000	82,350	823,497	Cash capital increase by NT\$ 100,000 thousand	-	Jin-Guang-Zheng-Yi-Zi No. 0980068988 issued on March 15, 2010
June 2010	15.85	150,000	1,500,000	82,840	828,402	Cash capital increase by NT\$ 2,285 thousand	-	Jin-Guang-Zheng-Yi-Zi No. 0960068163 issued December 4, 2007
September 2010	15.85	150,000	1,500,000	83,069	830,687	Cash capital increase by NT\$ 75,881 thousand	-	Jin-Guang-Zheng-Yi-Zi No. 0960068163 issued on December 4, 2007
November 2010	15.85	150,000	1,500,000	83,086	830,862	Cash capital increase by NT\$ 17 thousand	-	Jin-Guang-Zheng-Yi-Zi No. 0960068163 issued December 4, 2007
February 2011	15.85	150,000	1,500,000	83,161	831,612	Cash capital increase by NT\$ 750 thousand	-	Jin-Guang-Zheng-Yi-Zi No. 0960068163 issued December 4, 2007
July 2014	11	150,000	1,500,000	84,134	841,339	Corporate bond conversion of NT\$9,727 thousand	-	Jin-Guang-Zheng-Yi-Zi No. 1000045352 issued on September 27, 2011
August 2014	11	150,000	1,500,000	85,307	853,066	Corporate bond conversion of NT\$11,727 thousand	-	Jin-Guang-Zheng-Yi-Zi No. 1000045352 issued September 27, 2011
August 2015	10	150,000	1,500,000	86,416	864,156	Capital increase by NT\$11,900 thousand through earnings	-	Jin-Guang-Zheng-Yi-Zi No. 1040030988 issued on August 13, 2015
April 2019	12.29	150,000	1,500,000	94,829	948,289	Corporate bond conversion of NT\$84,133 thousand	-	Ching Shou Shang Tze No. 10801038870 issued on April 9, 2009
May 2019	12.29	150,000	1,500,000	96,652	966,515	Corporate bond conversion of NT\$18,226 thousand	-	Ching Shou Shang Tze No. 10801052500 issued on May 17, 2009
February 2022	15.72	150,000	1,500,000	104,689	1,046,858	Corporate bond conversion of NT\$80,174 thousand	-	Ching Shou Shang Tze No. 11101017520 issued on February 9, 2021
April 2022	15.72	150,000	1,500,000	107,466	1,074,657	Corporate bond conversion of NT\$27,799 thousand	-	Ching Shou Shang Tze No. 11101062090 issued on February 9, 2021
December 2022	22.04	200,000	2,000,000	107,507	1,075,065	Corporate bond conversion of NT\$900 thousand	-	Ching Shou Shang Tze No. 11230068710 issued on April 27, 2023
October 2023	21.43	200,000	2,000,000	107,978	1,079,778	Corporate bond conversion of NT\$10,100 thousand	-	Ching Shou Shang Tze No. 11330049670 issued on April 18, 2024
November 2023	21.43	200,000	2,000,000	109,532	1,095,317	Corporate bond conversion of NT\$33,300 thousand	-	Ching Shou Shang Tze No. 11330049670 issued on April 18, 2024
February 2024	21.43	200,000	2,000,000	109,560	1,095,597	Corporate bond conversion of NT\$600 thousand	-	Ching Shou Shang Tze No. 11330049670 issued on April 18, 2024
March 2024	21.43	200,000	2,000,000	109,732	1,097,324	Corporate bond conversion of NT\$3,700 thousand	-	Ching Shou Shang Tze No. 11330049670 issued on April 18, 2024
March 2024	21.43	200,000	2,000,000	113,573	1,135,728	Corporate bond conversion of NT\$82,300 thousand	-	Ching Shou Shang Tze No. 11330108650 issued on July 26, 2024
July 2024	21.43	200,000	2,000,000	113,578	1,135,775	Corporate bond conversion of NT\$100 thousand	-	Ching Shou Shang Tze No. 11330210890 issued on December 6, 2024
August 2024	21.13	200,000	2,000,000	113,582	1,135,822	Corporate bond conversion of NT\$100 thousand	-	Ching Shou Shang Tze No. 11330210890 issued on December 6, 2024
August 2024	17.60	200,000	2,000,000	121,582	1,215,822	Cash capital increase by NT\$ 140,800 thousand.	-	Ching Shou Shang Tze No. 11330210890 issued on December 6, 2024
April 2026	11.13	200,000	2,000,000	137,582	1,375,822	Cash capital increase by NT\$ 178,080 thousand.	-	Ching Shou Shang Tze No. 1530055330 issued on April 22, 2026

2. Types of Share

March 31, 2026

Types of Share	Authorized Capital			Remarks
	Outstanding shares	Unissued shares	Total	
Registered Common Stock	137,582,157	62,417,843	200,000,000	Shares of listed companies

Note: In accordance with the Company's Articles of Incorporation, the Company has an authorized capital of 200,000,000 shares, among which 4,700,000 shares are reserved for the exercise of stock options for employees.

(2) List of major shareholders

April 14, 2026

Name of Major Shareholders	Shares	Number of Shares(share)	Shareholding ratio
Lin, Chen-Yang		7,035,170	5.11%
Digiland Investment Inc.		6,862,457	4.99%
Huang, Chin-Hsiung		6,458,753	4.69%
Huang, Chin-Chi		5,028,465	3.65%
Li, Yeh-Hsu		3,810,526	2.77%
GB Investment Co., Ltd.		3,306,105	2.40%
Lin, Chao-Mao		2,496,000	1.81%
Zeng, Yi-Chun		2,480,000	1.80%
Yongsheng Investment Inc.		2,344,574	1.70%
Chen, Hong-Da		1,319,930	0.96%

(3) Company Dividend Policy and Implementation Status

1. Dividend policy :

The dividend policy of the Company's Articles of Incorporation is defined as follows :

The Company shall first set aside 10% of its annual net income as legal reserve, except when the legal reserve has reached the Company's paid-in capital, and shall set aside a special reserve in accordance with the Company's operating needs and laws and regulations, and the remainder, except for the payment of dividends, shall be distributed to the shareholders in accordance with the proposal for distribution of earnings prepared by the Board of Directors. The Board of Directors shall prepare an appropriation of earnings and submit it to the shareholders for resolution. Based on financial, business and operational considerations, the Company may set aside 10% or more of the distributable earnings for dividend distribution to shareholders, but may not distribute the distributable earnings if the amount is less than \$5 million. Dividends to shareholders may be distributed in cash or in shares, with cash dividends not less than 10% of the total dividends.

2. Dividend distribution status of the proposed dividend at the shareholders' meeting : No dividend was distributed.

3. Material changes in dividend policy are expected: None.

(4) Effect of the proposed stock dividend distribution on the Company's operating performance and earnings per share: The loss appropriation for FY 2025 as resolved by the Board of Directors on March 10, 2026 is not applicable as there is no stock dividend distribution.

(5) Remuneration Paid to Employees, and Directors :

1. Percentage or range of remuneration paid to employees and directors under the Articles of Incorporation :

According to the Company's Articles of Incorporation, the Company shall set aside 5% to 15% of the annual profit as remuneration to employees and not more than 3% as remuneration to directors and supervisors. However, if the Company has accumulated losses, the amount of compensation shall be reserved in advance.

2. Estimated basis for the estimated amount of employees and directors' remuneration in the current period, the basis for calculating the number of shares for employee compensation distributed by stock, and the accounting treatment if the actual distribution amount is different from the estimated amount : The remuneration of the Company's employees in FY 2025 was not distributed.

3. Remuneration distribution approved by the Board of Directors :

(1) The amount of employees' remuneration and directors' and supervisors' remuneration distributed in cash or stock. If the amount differs from the amount estimated in the year in which the expense is recognized, the amount of the difference, the reason for the difference and the treatment of the difference should be disclosed : The remuneration of the Company's employees in FY 2025 was not distributed.

(2) Amount of employee remuneration distributed in stock and its proportion to the aggregate of net income after tax and total employee remuneration in the individual or individual financial statements for the period : Not applicable.

4. Actual distribution of remuneration to employees and directors in the previous year :

Unit : NT\$ thousand

Earnings distribution for FY 2024		Resolution Distribution	Actual distribution
Date of approval of shareholders' meeting		May 29, 2025	
Employee Stock Dividend	Total number of shares distributed (shares)	—	—
	Total distribution amount	—	—
Employee cash dividends		—	—
Directors' and Supervisors' Remuneration		—	—

(6) Repurchase of the Company's Shares: None.

2. Status of corporate bonds (including overseas corporate bonds) :

(1) Issuance of Corporate Bonds

A. The fifth domestic unsecured convertible corporate bond

Types of Corporate Bonds	The fifth domestic unsecured convertible corporate bond
Date of issuance (processing)	September 2, 2024
Value	NT\$100,000
Issuance & Conversion Location	Not applicable
Issue Price	NT\$ 100
Total Value	NT\$150 million

Interest rate	Annual coupon rate 0%	
Maturity	3-year term, expiry date: September 2, 2027	
Guarantee Agency	—	
Trustee	Hua Nan Commercial Bank Ltd.	
Underwriting Agency	DXN General Securities Co., Ltd.	
Certifying lawyer	Handsome Attorneys -At-Law	
Certifying CPA	KPMG CPAs, Ou, Yao-Chun, Wang, I-Wen	
Repayment Method	Except for conversion or redemption in accordance with the conversion method, the principal shall be repaid in cash within 10 business days after the remaining maturity date.	
Outstanding principal	NT\$150 million	
Terms of redemption or early Repayment	Please refer to the Company's fifth domestic unsecured convertible bond issuance and conversion regulations.	
Restrictive Clause	Please refer to the Company's fifth domestic unsecured convertible bond issuance and conversion regulations.	
Name of credit rating agency, rating date, corporate bond rating results	Not applicable	
Other rights attached	Amount of ordinary shares, overseas depositary receipts or other marketable securities converted (exchanged or subscribed) up to the date of publication of the annual report	The Company's issued and outstanding corporate bonds are the fifth domestic unsecured convertible bonds with a outstanding balance of \$150,000,000 as of March 31, 2026, and the latest conversion price is \$23.78. Assuming that the creditors of each convertible bond convert all of the bonds at the conversion price, 6,307,822 shares of the Company's common stock (\$150,000,000/\$23.78) would be convertible, based on the number of issued and outstanding shares of the Company as of March 31, 2025 of Based on the number of issued and outstanding shares of the Company as at 31 March 2026 of 137,582,157 shares plus the number of convertible shares, the dilution ratio was 4.38%, which was not significant and did not yet have a material impact on shareholders' equity.
	Issuance and Conversion (Exchange or Subscription) Method	Please refer to the Company's fifth domestic unsecured convertible bond issuance and conversion regulations.
Issuance and conversion, or share subscription method, issuance conditions may dilute the equity and the impact on existing shareholders' rights and interests	None.	
The name of the custodian institution for the subject of the exchange	Not applicable	
Number of common shares converted as of March 31, 2026	0 shares	

(2) Information of Convertible Corporate Bonds

A. The fifth domestic unsecured convertible corporate bond

Types of Corporate Bonds		The fourth domestic unsecured convertible corporate bond	
Year		FY 2025	Current year as of March 31, 2026
Item			
Market price of conversion (Note)	Highest	NT\$102.50	NT\$100.00
	Lowest	NT\$95.00	NT\$94.05
	Average	NT\$98.70	NT\$97.30
Conversion price		NT\$23.78	NT\$23.78
Issuance (processing) date and conversion price at the issuance		Issue date : September 2, 2024 Conversion price at the issuance : NT\$23.78 issued	Issue date : September 2, 2024 Conversion price at the issuance : NT\$23.78 issued
Method to fulfill the conversion obligation		Issue new shares	Issue new shares

(3) Exchange of corporate bonds: None.

(4) Summary report of corporate bonds issued: None.

(5) Information of corporate bonds with stock options: None.

3. Issuance of Preferred stock: None.

4. Issuance of Depository Receipt: None.

5. Issuance of Depository Receipt: None.

6. Status of Employee restricted stocks: None.

7. Status of issuance of new shares in connection with Mergers and Acquisitions: None.

8. Status of implementation of the capital utilization plan: Not applicable.

V.Operation Overview

1.OPERATIONAL HIGHLIGHTS

(1) Business scope

1. Major content of business operations in the Company :

- Computer and Peripheral Equipment.
- Other Machinery Manufacturing.
- Electronic Component Manufacturing.
- Wholesale of Drugs, Medical Goods.
- Wholesale electronic materials.
- International Trade.
- Product Designing.
- Import and export business.
- All business activities that are not prohibited or restricted by law, except those that are subject to special approval.

2. Current major product items and their operating proportion:

Unit: NT\$ thousands:%

Key Products	FY 2025	
	Turnover	Proportion (%)
Cable assemblies (including connectors)	2,415,389	80.39
External Storage Device	138,693	4.62
Others	450,309	14.99
Total	3,004,391	100.00

3. Plan to develop new products (services)

(1) Cable assemblies (including connectors)

A. Extension of Original Customized Products

The main changes in the application of USB4 EPR, PD3.1, and HDMI 2.1 Premium products are to meet the special functions and small size of products such as NB, AIO, Desktop PC, Docking, and cell phone flash charging, which are different from the general standard USB3.2/2.0 and HDMI. According to the arrival of USB4 EPR era, Smart Phone, NB, Desktop PC, car harnesses need high-speed data transfer and high-current charging, USB4 Spec has reached 40Gbps high transmission standard interface and increased 48Vx5A=240W high-current charging. The high speed transfer I/O products must work closely with the customer's R&D department to help provide the products and technical services that the customer needs at the first time of the customer's R&D. This is the key to win.

Regarding the European Union's IEC-62680 regulation, the control of fluorinated substances (PFAS) is mandatory for consumer products because these chemicals are used in the development of products with non-stick and anti-fouling properties. These PFAS-based chemicals are also widely used in Cable products to meet high frequency characteristics. PFAS is very stable, known as 'persistent' in the environment, and has excellent properties for product characterization, so research and development of alternative materials to replace PFAS is underway.

HDMI Forum, Inc. announced the upcoming release of HDMI Specification Version 2.2 in 2025. The new HDMI specification provides enhanced options for the vast HDMI ecosystem and more advanced solutions for creating, distributing and receiving the best end-user experience. The new technology now and in the future provides content producers such as TV, movie and game studios with higher quality options while supporting multiple distribution platforms. Higher 96Gbps bandwidth and next-generation HDMI Fixed Rate Link technology provide best audio and video for various applications. End users can trust that their displays support native video formats in the best possible way and can deliver a seamless and reliable experience.

B. New product development:

- (A) Thunderbolt5 Passive cable Coaxial 0.8~1.5m
- (B) Thunderbolt5 Active Cable. Coaxial 2.0m
- (C) Research on PFAS Alternatives
- (D) HDMI 2.2 Specification
- (E) High-Speed Cables for Cloud and AI Servers
- (F) USB 4 TO PCI-e M.2 SSD
- (G) Wi-Fi extend
- (H) NAS for Media

(2) Electronic digital peripheral products

- A. Storage (External Storage Products) : Data storage solutions include technologies and methods to effectively store and manage digital data, ensuring easy search and long-term retention. External storage systems play a key role in these solutions, providing businesses and individuals with scalable, portable and secure storage options to manage ever-growing volumes of data, the warehouse for digital file storage has always been a key product for the Electronic Business Division. They include M.2 SSD Storage, encrypted storage, external SSD storage based on Thunderbolt 3 protocol, Network Attached Storage (NAS).
- B. Docking (interface expansion dock): With NB's pursuit of slimness and lightness, its products have eliminated many interface ports, and Docking products help expand the connectivity options for laptop and make it a more feature-rich device by adding ports such as Ethernet LAN ports, additional USB ports and video connections. The main update is the USB Type-C will take the USB4 specification to increase bandwidth to 40Gbpsu as well as add USB -PD (USB Power Delivery Specification) power supply to provide up to 240W to USB Type-C connected devices.
- C. Wi-Fi (based on 802.11 a/b/g/n/ac/ax connection application type products): Over the years, the WiFi 802.11ac module self-developed by the Electronics Division has been equipped in a wide range of storage and network devices. This year, the module will be designed with more powerful performance to enhance the transmission and user interface, and add more diversified applications, focusing on the needs of different groups of people. Moreover, in terms of network application, for families in home life, Wi-Fi Extender products launched in 2023, which not only extend the reach of wireless signals at home, but also will be upgraded in 2025 with more storage devices to provide composite functions and enhance the performance of the product to meet the needs of our customers.

(II) Industry Overview

1. Current status and development of the industry

(1) Cable assemblies (including connectors)

EU Announces Type-C Interface for All Devices, The European Union has always been committed to green and environmental protection, such as the pursuit of a unified interface for electronic products, and the hugely popular USB-C is clearly the best choice at the moment, so the EU has decided to pass a decree to make the USB-C interface mandatory for all electronic products. Regarding the demand of IEC62680, the EU finally made an official announcement in 2026The decree comes into effect and all electronic products sold in the EU will be required to use the USB-C interface.

This list from the EU includes devices such as mobile phones, tablets, digital cameras, headsets, game consoles, e-readers, keyboards and mice, screens, etc., all of which must use the USB-C interface, and all laptops will be required to use the USB-C interface by 2026. It can be said that the EU's move to unify all interfaces is a huge step forward. After all, due to the immaturity of the technology in the past, there were dozens of interfaces on the market, and then with the rise of USB, basically Micro-USB, Apple's Thunderbolt, and Type-C became the three major common interfaces, and Micro-USB is almost eliminated. Although some other products still continue to adopt existing specifications, they are expected to be fully replaced by 2026. According to market research and industry forecasts for the global USB Type-C market from 2025 to 2037, the USB Type-C market size was valued at approximately US\$4.66 billion in 2024 and is projected to reach approximately US\$81.31 billion by 2037, representing a compound annual growth rate (CAGR) of approximately 24.6% during the forecast period (from 2025 to 2037). The USB Type-C industry size is estimated to reach approximately US\$6.67 billion in 2025.

The growth of this market is primarily attributable to USB Type-C's superior data transmission capabilities compared to other interface technologies. USB Type-C has now become widely adopted across various electronic devices, including phones, tablets, notebook computers, and MacBooks, all of which are equipped with USB Type-C ports. In most cases, USB Type-C ports are built based on the USB 3.1 Gen 2 data transmission standard, supporting data transfer speeds of up to 10 Gbps, which is approximately twice the speed of USB 3.0 and USB 3.1 Gen 1 standards. According to industry sources, USB Type-C is capable of transmitting data at speeds of up to 10 Gbps while supporting power delivery of up to 100 watts. In addition, the widespread adoption of USB Type-C in smartphones and tablet devices continues to drive market growth. USB Type-C connectors can be used with USB-C chargers and support fast charging capabilities of up to 240 watts. Furthermore, USB Type-C and HDMI cables enable data and audiovisual transmission between smartphones or tablets and televisions or display monitors. The increasing penetration of smartphones, tablets, and internet connectivity is expected to further stimulate market demand during the forecast period. According to market statistics, more than 68% of smartphones manufactured globally in 2019 were equipped with USB Type-C charging ports. The increasing demand for USB Type-C devices is also driven by their broad applications across various end-user industries, including robotics, automotive, aerospace, wireless communications, computing, and consumer electronics. Global shipments of USB Type-C devices reached approximately 11 million units in 2021. Continuous investment in research and development, together with rapid advancements in voltage regulation and thermal protection technologies, is expected to significantly increase demand for USB Type-C products and accelerate market expansion. USB Type-C technology is now widely applied in aircraft, automotive

systems, smartphones, and tablet devices. Technological advancements in automotive infotainment systems are also expected to create significant growth opportunities for USB Type-C applications within the automotive industry. Recent developments in automotive infotainment technologies have become one of the key growth drivers for the USB Type-C market in the coming years. Advancements in automotive infotainment systems contributed to approximately 7% growth in market demand in 2019. High-efficiency and high-speed data transmission capabilities remain one of the key factors driving market expansion. According to industry sources, USB Type-C supports data transmission speeds of up to 10 Gbps.

The Company possesses mature expertise and technological capabilities in applications related to cloud computing and AI servers, data centers, and liquid cooling solutions. Leveraging Joinson's wire drawing technology, molding and assembly capabilities, as well as quality assurance through advanced testing equipment such as TDR and VNA, the Company provides customers with stable and high-performance products.

(2) Electronic Digital Peripherals

With the proliferation of online services such as social networking sites and digital music, digital information and video content are becoming more and more accessible. It is estimated that more than 1 billion MP3 songs circulate on the Internet every day, more than 100 million videos are downloaded from YouTube, and each piece of native digital data is copied more than three times on average. With the continuous production, copying and transmission, the explosive growth of digital information content has driven users' demand for digital data storage and sharing. The traditional hard drives built into personal computers are no longer able to meet the needs of users for digital data storage and backup, resulting in the rapid growth of the external storage market. According to IDC, by 2023, more than 50% of the world's GDP will be contributed by "digitization", which includes digital products, services, technologies, operations, and relationships. In order to establish stronger competitiveness in the future digital economy, the digital transformation of enterprises is a definite development direction, and a large number of enterprises will invest in upgrading their IT hardware and software to cloud their existing digital applications. According to IDC/EMC statistics and predictions, by 2020, the global digital data volume will reach 44ZB (Zettabytes, 1ZB = 1,000EB, 1EB = 1,000PB, 1PB = 1,000TB, so 1ZB will be equal to 1 billion TB), an increase of more than 50 times of the data volume since 2010. The total data volume is expected to increase more than 10 times to 456ZB from 2020 to 2030 and the data will need to be saved through storage commodities, NAND Flash, optical media or tapes. This trend will also be a boon to the demand for storage devices, and the overall market will grow at a multiplier.

General consumers usually use external storage devices, depending on their storage media, there are two main categories: external hard drives and external optical drives. Laptop computers require lighter and thinner size and cannot be equipped with CD-ROM drives in recent years, so consumers usually purchase external CD-ROM drives to satisfy the demand of watching videos and reading/storing data with CD-ROMs. The demand for optical discs and optical disk drives is declining year by year. External hard disk drives can be divided into traditional mechanical hard disk drives (HDD) and solid state disks (SSD), which are light, thin, short, small, and easy to carry. HDD is currently the mainstream 2.5-inch specification, and the price per unit of storage is lower than SSD, so it is more suitable for storing a large amount of file data. However, HDD uses mechanical rotors to transport the discs and mechanical axes to control the heads, so there are technical limitations such as poor shock resistance, high power consumption and large size. SSDs are similar in appearance to 2.5-inch HDDs, and use flash memory

chips such as DRAM or NAND Flash as the storage carrier. However, flash memory has a limit on the number of reads, and if the maximum number of reads is exceeded, all stored data will be lost, and the price per unit of storage is higher than HDD.

2. Relationship between upstream, midstream and downstream industries

The information industry in Taiwan is becoming more and more sophisticated in terms of manufacturing technology and mature in terms of professional division of labor, and the information industry system can be said to be quite complete. The Company's cables (including connectors), storage devices and other peripherals are in the midstream of the overall information industry. The location of our products in the information industry and the relationship between the upstream, midstream and downstream industries are summarized as follows:

(1) Cable assemblies (including connectors)

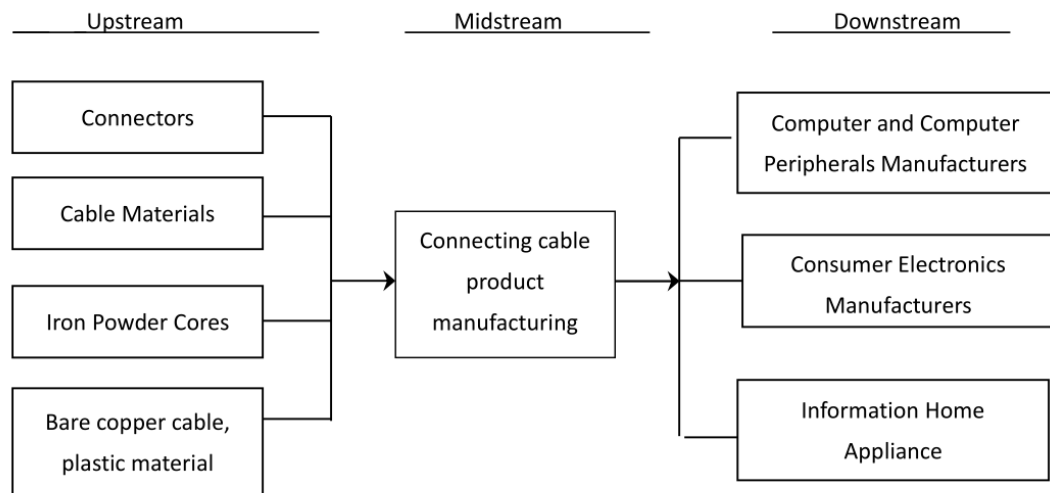

Connector assembly is the process of cutting, laser peeling, laser welding, assembling and molding of connectors, cable materials, powder cores and plastic materials, and then strictly tested and inspected by TDR and NA. After completion, we sell them to computer and computer peripheral manufacturers, consumer electronics manufacturers, and information appliances subscribers, among which our main raw material connectors are developed in-house.

(2) Electronic Digital Peripherals

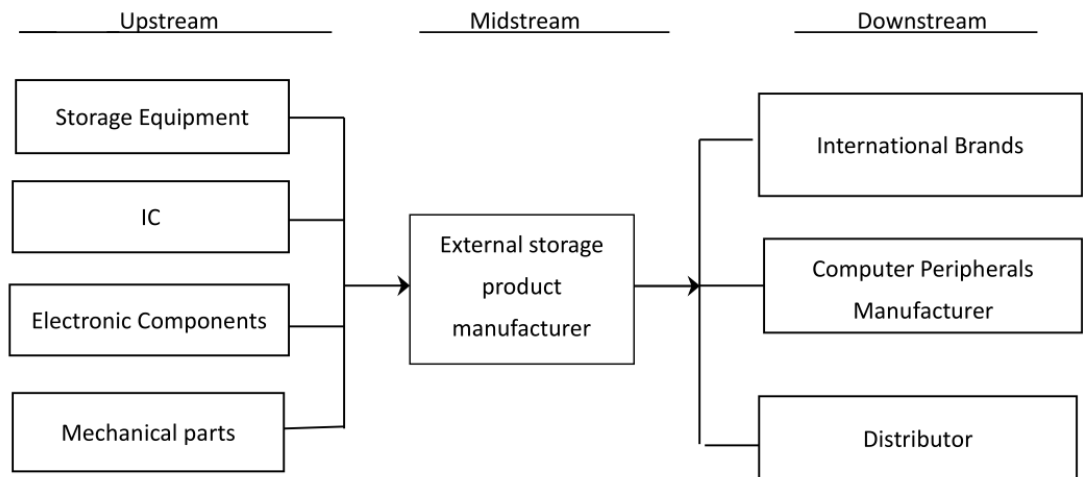

Our electronic digital peripheral products are purchased from ICs, electronic components, mechanical parts, storage devices (including and not limited to hard drives and CD-ROMs), etc., designed and developed, then strictly tested and tested, and after completion, promoted and sold to international brand manufacturers, computer peripheral manufacturers and distributors, etc.

3. Various development trends and competition of products

(1) Product Development Trends

a. Related Development Strategies for Type C

The demand for USB Type-C devices is growing due to USB Type-C devices' wide adoption in various end-user industries such as robotics, vehicle, aerospace, wireless, counting and consumer electronics. In terms of aircraft type segmentation and analysis of global USB Type-C market demand and supply, the market is categorized into commercial aircraft, private aircraft, and other aircraft. Among these segments, the commercial aircraft segment is expected to account for the largest market share by the end of 2037. Growth in this segment is primarily driven by the increasing number of commercial aircraft worldwide and the rising demand for passenger transportation. According to statistics published by the International Civil Aviation Organization (ICAO), the total number of passengers carried on scheduled flights increased by 3.6% from 2018 to 2019, reaching 4.5 billion passengers in 2019. Statistics also indicate that the number of departures increased by 1.7% during the same period.

The global USB Type-C market is also segmented and analyzed by connector type, including USB 2.0, USB 3.0, USB 3.1, and USB 3.2. Among these, the USB 2.0 segment is expected to account for the largest market share throughout the forecast period by the end of 2037, primarily due to the large installed base of devices equipped with USB 2.0 technology currently available in the market. In addition, the USB 3.2 segment is expected to grow at a significant rate during the forecast period. USB 3.2 is an upgraded version of USB 3.1 and supports data transmission speeds of up to 10 Gbps.

In response to the trend of terminal 3C products becoming thinner and shorter, the development trend of high value-added, miniaturised, multi-functional, multi-media and wireless will continue to escalate, and the demand is increasing. 5G NR (Sub 6G) advanced version of the network speeds will be up to 10~100 times that of 4G user-centric, more flexible, intelligent, efficient, and open Sub 6G new state of the art network, in the field of wireless networking and communications. Developments in

the field of wireless networking and communications include Wireless Local Area Network (WLAN), wider channels WiFi 6E, the 7 GHz band, offers more available channels, each up to 160 MHz wide, which is much wider than the 80 MHz of the 5 GHz band or the 20 MHz of the 2.4 GHz band. This allows WiFi 6E to deliver faster transmission speeds with less signal overlap and interference, a cleaner band, and greater compatibility. Multiple-Input/Multiple-Output, Wireless Wide Area Network (WWAN) 3G, 4G fourth generation communication, LTE (Long Term Evolution), and 4G. LTE (Long Term Evolution), Wireless Personal Area Networks (Wireless Personal Area Networks), WiMAX (Worldwide Interoperability for Microwave Access), Ultra Wide Band technology (Ultra Wide Band), Global Position System (GPS), etc. Integrating information and communication innovation technology, combining cloud and Internet of Things technology application, using 4G+5G technology to develop a new smart life, leading the industry and society towards a smart city." Artificial intelligence (AI), Internet of Things (IoT), autonomous driving, VR and AR integration, smart wearable devices, etc. have become the mainstream of future antenna product development and business opportunities. The latest generation of Wi Fi will use spectrum resources across all 3 frequency bands (2.4GHz, 5GHz and 6GHz). While Wi Fi 6E aims to respond to the growing number of devices, Wi Fi 7 aims to deliver amazing speeds per device with greater efficiency. The Company's research and development continues to keep up with the latest wireless technology. The antenna is a high-end non-standard specification customization product, our antennas are currently designed to provide:

- (a) Fast design and rapid prototyping service.
- (b) Establish exclusive 3D CHAMBER (microwave test chamber) to shorten test, design time and testing and proving time with customers.
- (c) Patented F Type & Coupler Type & PATCH antenna design structure.
- (d) Provide system factory electronics, mechanism assembly advice and production review (ON SITE SUPPORT) to reduce the number of design changes for customers.
- (e) To win the recognition of international manufacturers with high standard of production quality and rapid production delivery.
- (f) Planning vertically integrated component development and assembly to enhance competitiveness.
- (g) Light-curing 3D printing machine with high resolution up to 28 microns, creating a large print size of 21.8 x 12.3 x 23.5 cm to assist customers with their mockup and hold needs.

Based on our high level of vertical integration, we are able to effectively enter the emerging meta-universe of products with the combination of wired products and wireless products resources. We also lead the market by developing products for end-users, and look forward to high-speed wiring harnesses, power products, and wireless products, all of which are indispensable to effectively meet the needs of our customers, and to tailor and customize our products to meet customer and market demands.

c. Development trend of connectors/automotive connectors

The company has invested in the automotive customization market with its professional R&D and manufacturing capabilities in simulation software for structural stress, mould flow, temperature rise and high frequency SI to avoid competition from standard products. Moreover, the company has integrated its internal electronics department to integrate the development of connector modules for customers, providing customers with professional services that are not typical connector manufacturers, and establishing the ability to jointly develop and compete with customers.

d. Customised Cables

We provide design and processing services for special customised requirements, from manufacturing and processing to sales of various computer peripherals, LCD monitors, power supplies, audio, automotive communications, medical equipment, industrial control, cloud computing servers, data centers and other wires. We have many years of experience in designing and manufacturing products to meet the needs of our customers in the highly competitive electronics market, and we can provide you with the high efficiency and service you expect from small-lot to large-lot production.

B. Electronic Digital Peripherals

a. External Storage Product Development Trends

External storage has made significant speed changes in terms of protocol and particle advances, and the advent of USB4 not only represents an increase in speed, but also incorporates the features of Thunderbolt™ 4 to further expand the possibilities of connectivity. The interface for high-end products is bound to be USB 4 and Thunderbolt, and PCIe for PCs has also received the 5.0 update, and 4.0 has also supported its specifications for external storage products.

b. Interface docking station product development trend

The current market of HUB docking station products has grown from a dark horse in the niche market through rapid development in recent years to a mainstay of the cable industry today, with its market sales increasing year by year. Especially with the promotion of many Amazon sellers in 2020, the epidemic era has pushed many HUB dock manufacturers to the peak, and many chip makers have released a variety of products to match the rapid development of the HUB market. The beginning of all of these is from Apple's streamlining of the interface in its MAC product line to the extreme. As a giant in the technology field, Apple's new product line expansion is a foretaste of the future development direction of the industry. After more than four years of development, the HUB docking station has become one of the fastest growing products in 3C consumer electronics peripherals. USB4 has already been launched in 2022, Type-C multi-functional docking station solves the problem of more peripherals and efficiently transmits large amount of data, the new docking station appears to support 40Gb/s data transmission, 5K/8K HD video, PD3.1 EPR and increase charging power up to 240W charging power. The rapid development of HUB docking stations has also driven the industry upgrade of related supply chain manufacturers, where the expansion of application scenarios and the upgrade of supporting supply chain, such as master control chips, power management ICs, cable structure updates and other technological advances have brought more opportunities for HUB functions.

c. WiFi product development trends

Wi-Fi, as one of the most important connectivity methods for the IoT, will benefit from the development of the IoT first. Wi-Fi MCUs are accelerating the penetration from home appliance applications to non-home appliance applications, including lights, sockets, curtains, door locks, smart wearable products, etc. Regarding IoT chip applications, Wi-Fi MCUs are mainly used in home appliances, home IoT accessories (e.g. lights and sockets), and industrial IoT in smart homes. According to the survey, home Wi-Fi products account for 69% of IoT applications and industrial applications account for 17%.

Compared to Wi-Fi 6, Wi-Fi 7 provides faster data transfer speeds and higher throughput, and supports the growing demand for high bandwidth applications. Wi-Fi 7's 320MHz bandwidth in the 6GHz band provides wider channels to transmit more data, and QAM uses discrete points in constellation diagram to transmit data over the radio waves. Each discrete point represents a certain number of data bits: the more discrete points allowed, the more data can be transferred. Wi-Fi 7 allows up to 4096QAM, also known as 4KQAM, with 12 data bits per symbol. 4096QAM provides higher data transfer rate, which is critical for Wi-Fi coverage to consistently serve many clients and ensure fast and reliable in high-density deployment scenarios. The effect of channel noise is a major challenge in this type of high-level modulation. Therefore, 4096QAM requires a high signal-to-noise ratio (SNR) to achieve high data throughput.

(2) Competitive situation of products

A. Cable assemblies (including connectors)

There are many industries that use connectors, i.e., as long as there are electronic products with connection signal transmission, there will be a continuous need for cables and connectors, such as personal computers, computer peripherals, smart phones, digital cameras, medical equipment, automotive electronics, industrial computers, cloud and AI servers, data centers and various other consumer electronics and information appliances and peripheral electronics, covering almost all important industries. Therefore, the development trend and innovation of various electronic hardware and equipment and transmission methods and capabilities have driven various demands of the connectivity industry in various periods. The ability of the connection industry to keep abreast of the market dynamics of downstream applications and to introduce new products with corresponding specifications in a timely manner provides the best profit and market opportunities for cable and connector manufacturers. We have the ability to develop and respond to the rapid development of products, which shortens the product development time and expands new products to meet the diverse needs of portable electronic products, and on the other hand, we also design customized products for customers through individualized services, which makes our products competitive. Moreover, we actively meet the expectations of our customers in terms of delivery time, so that we can be aligned with their thinking and respond quickly to the ever-changing market.

B. Electronic Digital Peripherals

The information, communication, and IA industries are diversifying in terms of products and demands for specifications, and customers increasingly require outsourcing companies to provide a wider range of services, including product design, manufacturing, quality control, and after-sales services. Our company has the ability to develop electronics, software and machinery. According to the market demand, we are

always changing our product contents and developing towards high-end and high value-added products. Our complete product portfolio is conducive to the flexibility of our operations and increases our ability to respond to rapid changes in product cycles.

The company's competitive strategy for external storage devices is to design and develop with existing customers, and with limited R&D resources, to develop products with new industry technologies to enhance innovation value, and to introduce cost-reducing designs, and to cooperate with suppliers strategically to focus on purchasing volume, and to create efficiency with volume to price. Product design is based on modularization and common thinking, with the same electronic circuit design but with different appearance for different customer proposals, so that the efficiency of research and development can be enlarged and the quantity increased to reduce costs; expand the overall service, from design and development, research and development verification, production and manufacturing, quality control, etc., so that customers can be more recognized; and continue to recruit excellent R & D personnel of all kinds to enhance competitiveness.

C. Antenna Products

Wireless communication must go through the antenna as the gateway to send and receive, so the growth of the antenna is closely related to the development of various transmission technologies. For example, (1) the number of 11g to 11n antennas will increase from 2 to at least 3 MIMO antennas, an increase of 50%, which is the driving force for the growth of WLAN(Wireless Local Area Networks) antennas; (2) GPS The use of GPS gradually from PND to handheld devices, such as cell phones also drive the growth of GPS antennas, and the growth of GPS applications in cell phones is significantly greater than PND; (3) cell phones, in addition to cell phone transmission signals, Bluetooth, WiFi, GPS integration is increasingly common; Bluetooth in addition to cell phone applications, devices, WiFi, GPS integration is also increasingly common. In addition to cell phone applications, Bluetooth devices are becoming more and more popular on NBs; (4) The rise of NFC is driving the demand for plastic money and small automatic debit spending; (5) 4G fourth-generation communication LTE (Long Term Evolution) antennas make cell phones not only limited to call functions, but also personal audio and video entertainment and (6) 5G 4GLTE advanced version to lead the industry and society to the smart city. Artificial intelligence (AI), Internet of Things (IoT), autonomous driving, VR and AR integration, and smart wearable devices; (7) Unmanned Carrier Sending and Receiving Antenna; (8) Antennas for Base Stations and Marine Special Vehicles are the mainstream and business opportunities for future antenna product development.

The development of sub 6g and Wi-Fi 6E in 2024 will focus on the design and development of sub 6g 5G, short for “5th generation mobile networks”, in line with new protocols and new market demands. According to the standards set by 3GPP (3rd Generation Partnership Project), an international communications standardization body, 10 times the speed is used to separate generations, so 5G network speed will theoretically be more than 10 times that of 4G. Many of the previous 3G and 4G generations are saturated, so the new generation of 5G will require more new frequency bands. According to the specifications defined by 3GPP, 5G is divided into two broad bands, with the 6GHz band as the boundary, and below 6GHz, or Sub-6, ranging from 450MHz to 6GHz, providing low-latency, Mbps-class Wi-Fi for home and business users. Wi-Fi 6E delivers high performance and low latency in dense environments such as transportation hubs and stadiums for augmented reality (AR)/virtual reality (VR), the Industrial Internet of Things (IIoT), crowded home networks or in high-capacity enterprise networks. The Wi-Fi Alliance expects Wi-Fi 6E to grow rapidly. Wi Fi 7

provides faster data transfer speeds and higher throughput and supports the growing demand for high bandwidth applications. Wi-Fi 7's 320MHz bandwidth in the 6GHz band provides wider channels to transmit more data

We have assisted our customers in developing a variety of sub 6g and Wi-Fi 6E built-in and external antenna products and added RF Cable, provided customized RF Conn and other products and have delivered samples. The product categories continue to be developed according to customer usage requirements. In 2026, the Company plans to add production equipment for antenna- and in-flight cable-related products in Taipei to support customers' mass production operations in Taiwan.

D. Customised cables and connectors

According to the new market demand and changes in the design and processing of special customised needs, whether it is from a variety of computer peripherals, LCD screen display, power supply, audio, automotive communications, medical equipment, industrial control, cloud computing, AI servers, and data centers needs of non-standard wire manufacturing and processing services. Years of product design and production experience in the highly competitive electronics market to provide a wide range of customer needs, from small quantities to large-scale production from wireless to internal customised cables and external USB cables, professional design and manufacturing to provide customers with efficient production capacity and service.

(3) Technology and Research Development Overview

1. Technology level and research development status of the operating business

(1) Cable/connector, RF Cable, RF antenna, car antenna, USB Type C peripheral product series :

We have been working in the connection cable industry for 40 years and have built up a strong foundation of R&D and production, which has won the recognition of various international manufacturers and established a deep customer base.

A. Based on the development of connecting wires in recent years, we have been able to integrate the industry upstream, from cable production to connector manufacturing and connector assembly, so that we can grasp the advantage of cost and the development of technology. Meanwhile, we can reduce cost and lead time, which will help to integrate efficiency and competitiveness. We have developed USB4 Cable, Type 2.0 male plug and board end female connector, flat cable, Type C long meter cable (Active cable), and AOC products, MCIO, Gen-Z, PCIe Riser Cable for LCD TV, AIO, Set Top Box, storage device, smart phone, power connector, and Docking. Applications in cloud computing, AI servers, and data centers are widely used across consumer electronics, PC industry, phones, and commercial electronic applications.

B. The challenge of future research and development will be towards higher frequency and speed, such as the USB4 (40G) specification target and the challenge of longer meters (50m/100m) of USB4 40G Active cable (active cable), this part of the challenge is also to meet the future IOT market and AI market needs of the big data era.

C. Focusing on the Southeast Asian market to satisfy the OOC (Out Of China) policy of European and American manufacturers, JEM has made an advance layout in Thailand to make Southeast Asia its future production base.

D. Our production facilities are designed by ourselves to improve efficiency and increase profits. Our company has the competitive advantage of upstream integration and technological breakthroughs in the period of rising raw materials. The Taipei R&D Center sets up a high-frequency laboratory including RF network analyzer, time domain reflection analyzer (TDR), and function generator. The RF Chamber is a microwave darkroom for testing 3D amplitude fields, as well as high-end 3D Pro-E, simulation software, and X-ray fluorescence spectrometer; a multi-functional stress analyzer for testing connectors to plug and unplug multi-functional machines; and an inductively coupled plasma atomic emission spectrometer for testing functional machines that analyze materials in compliance with RoHS (environmentally friendly materials). Our stress analysis and high-frequency technology ensures rapid development and accurate verification of connector/connector/RF antenna products.

E. JEM's innovative AC Power Inlet (IEC 60320 power outlet), self-designed production equipment, efficient production, newly acquired ball pressure tester, hot wire (flame resistance) tester, and high voltage leak testers have enabled JEM to move beyond DATA and low current voltage transmission to the full range of AC to DC power and DATA and low current voltage transmission.

(2) Electronic Digital Peripherals

A. R&D Capability

The professional integration of R&D capabilities from ID (appearance) drawing, mechanism design, electronic circuit design, layout, firmware development, EMI/EMC testing, packaging design, reliability testing, etc., link the product development process and product management capabilities to give the overall product design quality and enhance the added value of the product.

B. Engineering Technology Capability

We have complete and professional engineering development and validation capabilities, complemented by sophisticated instrumentation and rigorous processes to ensure the smooth transition from design to mass production of our own or customer-designed products. We also develop our own test software, test fixtures and construct engineering verification methods to increase production efficiency and ensure product quality.

C. Production Capability

We have solid and international standard management process and continuous improvement mechanism from SMT, DIP, assembly, testing, packaging, inspection to shipment. Especially, we have the most complete and efficient product testing platform for testing and verification of manufacturing products. According to the production, we have built the SMT complete process (0201), BGA general-purpose machine, AOI optical inspection machine, solder paste inspection machine, BGA X-ray inspection machine and other high-end equipment in 2016 to ensure the reliability and high quality of all products produced. In order to meet the demand of the PAD and cell phone market, we have added a class 10,000 clean room to meet the demand of our customers for clean product assembly.

2. Research and development expenses and technologies or products successfully developed for the most recent year and up to the date of publication of the annual report

Unit : NT\$ thousand

	FY 2025	FY 2026 Q1(Note)
R&D expenses B	160,130	43,369
Net revenue A	3,004,391	784,415
R&D expenses as a % of net revenue B/A	5.53%	5.53%

Note: The consolidated financial statements for the first quarter of 2025 were reviewed by the accountants.

The technology or product that was developed successfully.

Completion Time	Item
2025	<ol style="list-style-type: none"> 1. USB4 GEN4 80G Certification 2. Wireless Charging Coil Product Development 3. Antennas for Base Stations and Marine 4. Medical Wire and Specialty Wire for Industrial Controls 5. Customized RF Conn and other products

(4) Long-term and short-term business development plans

1. Short-term Development Plan

- (1) Develop USB4 GEN4 80G Certification; USB4 40G/80G and EPR (48Vx5A=204W) related products, including Cable Assembly, etc.
- (2) Thunderbolt5 Active Cable coaxial 1.8m ◦
- (3) Thunderbolt5 Active Cable coaxial 3.0m ◦
- (4) Regarding the manufacturing capability, we provide the most competitive products to our customers with our vertical integration strategy.
- (5) We continue to improve our quality and management capabilities in electronic R&D and manufacturing to increase production capacity in line with our business expansion.
- (6) We are committed to the development and management of environmentally friendly materials to meet the increasingly stringent environmental regulations in Europe, the United States and Japan, and to fulfill our corporate social responsibility.
- (7) We are strengthening our electronic manufacturing facilities to meet the demands of different industries for OEM. We will continue to optimize our U-line process to consolidate our advantage in the industry.
- (8) Develop Thunderbolt-related products, including docking stations, adapters, etc.
- (9) Develop WiFi category applications, starting from private cloud and slowly radiating to other IoT devices.
- (10) Develop MCIO coaxial cables to satisfy application requirements in the robotics industry.

2. Medium and long-term development plans

- (1) Develop semi-automatic and automatic production equipment to meet customer demands.
- (2) Develop HDMI 2.2 specification products, including Cable Assembly, etc.
- (3) Develop USB Type C Active Cable related products to fulfill meta-universe video/VR related accessories.

- (4) We will continue to enhance our R&D capabilities in electronic products, strengthen our firmware, and increase our application software development capabilities to build product differentiation capabilities.
- (5) Forecast the market demand trend, develop new products in advance, and train business talents at the same time.
- (6) Strengthen cooperation with customers for simultaneous development in order to grasp the market trend value exactly.
- (7) Increase the R&D budget to control the resources effectively and maintain the core value of R&D.
- (8) Strengthen the wireless research and development capability to steadily maintain the competitiveness of product design.
- (9) According to the trend of light, thin, short and small in the industry, we are strengthening our automatic process capability.
- (10) Cultivate excellent R&D talents and establish a global R&D structure.

II. Market and Sales Overview

(1) Market Analysis

1. Regions of sales of major products and services

Unit : NT\$ thousand

Item	FY 2024		FY 2025	
	Amount	%	Amount	%
Domestic Sales	202,235	7.15	236,387	7.87
Export	2,624,158	92.85	2,768,004	92.13
Total	2,826,393	100.00	3,004,391	100.00

2. Market Share

The sales value of the Company's cables and connectors was NT\$2,415 million in 2025. Based on the 2025 Taiwan Electronic Connection Association's estimate, the Company's market share was approximately 0.3% in 2025.

3. Supply and demand situation and growth of the market in the future

(1) Cable assemblies (including connectors)

The USB Type-C market is projected to grow by approximately US\$17.2555 billion from 2024 to 2029, representing a compound annual growth rate (CAGR) of approximately 15.6% during the forecast period. Comprehensive analysis of the USB Type-C market includes market size, forecasts, trends, growth drivers, challenges, and vendor analysis covering approximately 25 suppliers. The report provides an up-to-date assessment of the current market landscape, emerging trends, growth catalysts, and overall industry environment. Key factors driving market growth include the increasing adoption of premium smartphones in emerging markets, abundant availability of USB Type-C cables and accessories through online sales channels, and rising demand for smart wearable devices and IoT equipment.

Future development trends for USB Type-C include diversified applications, with USB Type-C connectors being widely adopted for charging, data transmission, video output, and audio transmission, demonstrating their multifunctional capabilities. In terms of high-speed transmission, USB 3.2 and USB4 standards support data transfer rates of up to 40 Gbps, satisfying the requirements for large file transfers and high-definition video transmission. In terms of power delivery, USB Type-C supports power output of up to 100 watts, meeting the fast-charging requirements of various devices. As USB Type-C adoption continues to expand, demand for related accessories, devices, and technological solutions is expected to increase accordingly, creating substantial business opportunities for manufacturers, innovators, and product designers. Future developments in USB Type-C technology are expected to continue enhancing user experience and expanding commercial opportunities, making it an important driving force within the technology industry.

With the rapid rise of the AI industry, Joinsoon is assisting customers in entering and participating in the AI ecosystem while establishing close relationships within the industry. Joinsoon possesses strong hardware capabilities, including advanced interconnect cable technologies. For high-speed AI server cables, the Company adopts industrial-grade cable materials and connector designs that support mainstream high-speed interfaces while delivering low-latency and highly reliable transmission performance. Engineering optimization has also been implemented for electromagnetic interference resistance and heat dissipation, thereby improving convenience for rack-

level wiring and maintenance. The Company further provides customized services, including cable length, interface specifications, and validation testing, while offering practical recommendations and delivery specifications based on customers' system architectures.

Whether for high-speed AI server cables or internal and external electronic connection cables, the Company's products are designed to provide high-quality and reliable connectivity solutions that meet customers' requirements for performance, compatibility, and validation.

2. JEM USB4 & USB3.2 Products

(2) Electronic Digital Peripherals

According to MIC's report, the hard disk drive (HDD) market is divided into PC applications (including desktop, notebook and server) and non-PC applications (including external hard disk drives, external optical drives, HDD recorders, gaming and car navigation systems, etc.). The following are descriptions of external hard drives, networked hard drives (NAS) and external optical drives :

A. External Storage Products

Data privacy is a technological trend in mobile hard drive boxes, which is especially important in the information age and knowledge economy.

Data-encrypted mobile hard drive cases are a useful product for users in industries such as data development, animation production, and finance. The current market is also accepting it gradually. Meanwhile, when information life is deepening, consumers who pay more and more attention to the privacy of their lives and work will accept encrypted mobile hard drive boxes more and more. For example, stockholders, product marketers, company executives, and parents who share a mobile hard drive with their children will increasingly see the usefulness of having an encrypted area on their mobile hard drive.

There are many encryption solutions in the market, including software encryption, fingerprint encryption, and RFID access control encryption technology. Here we highly recommend SecureDriveEx, an encryption software product from Taiwan's Super Future Software, which is relatively low cost, has no processing difficulties, and meets the user's requirements for easy use, and the actual encryption principle is realized through hardware, so there is no doubt about the security.

B. The Interface Docking station series :

The docking station as an option for users to expand the user interface to better utilize the multimedia capabilities of the smartphone will be the most important feature of the cell phone accessories, for future devices, proprietary interfaces can be integrated to create more docking station configurations. The development of future interface standards will play an important role in addressing these issues. The use of docking stations is expected to become increasingly widespread, while future docking stations will be upgraded to support broader application functionalities.

C. Antennas and Customised Cables/WiFi Category Products :

Smart home is an important application terminal for WiFi, and the expansion of its market size will drive the rapid development of WiFi. Under the background of the slow development of traditional consumer electronics terminal market, WiFi technology is gradually shifting its target application market and is focusing on penetrating the Internet of Things application scenario. WiFi technology is facing competition from NB-IoT, LoRa, Zigbee and other wireless transmission technologies in the IoT application scenario. The WiFi technology is at a disadvantage compared to NB-IoT and LoRa technologies in terms of power consumption and number of connected devices. Besides, the price of WiFi module has declined less than other technology module products, which is not conducive to its further application promotion in the field of Internet of Things.

4. Competitive Niche

(1) Technology development meets market demand and has a complete product line

Our company has a clear strategic position in terms of product competitiveness and is a complete connector product series and specification developer for handheld devices and external storage devices. Our R&D department continues to design customized products for customers' needs through individualized services, and our product development and design are well recognized by major manufacturers of downstream applications.

(2) Technology capability for rapid R&D and design process

Our company has the technology to develop and validate electronic and mechanical components, and also has strategic alliances with professional mold manufacturers. For product development, we design and develop products from product design, precision mold design, efficiency or automated assembly and inspection equipment, and accelerate the integration to establish a consistent process from design, manufacturing, to production. This vertical integration can shorten product development time, master key technologies, and control product quality. The rapid development of connector products and the flexibility to change production at any time are the winning factors for customers.

(3) Strict quality control, stable product quality

We have strict quality control and good and accurate process control during the manufacturing process to control the problems in time and reduce the defect rate of the products, so that the quality of the products can be properly controlled.

(4) The overseas subsidiaries are managed by the group, providing the key customers with better technical support and sales services nearby.

Based on the consideration of serving customers in close proximity, the Company has successively invested in Dongguan JEM MFG. In addition to enhancing the company's competitiveness in terms of delivery time and product price, we also provide better technical support and sales services to our key customers nearby, establishing an irreplaceable supply partnership. We have built a real-time information interoperability system to enable access and monitoring of information between subsidiaries and factories to achieve real-time management of all business, production, procurement, and physical management functions. Based on the consideration of serving customers in close proximity, the Company has successively invested in Dongguan JEM MFG. In addition to enhancing the company's competitiveness in terms of delivery time and product price, we also provide better technical support and sales services to our key customers nearby,

establishing an irreplaceable supply partnership. We have built a real-time information interoperability system to enable access and monitoring of information between subsidiaries and factories to achieve real-time management of all business, production, procurement, and physical management functions.

(5) Long-term solid customer partnerships

Our main customers are international manufacturers such as digital camera makers and global electronics assembly companies, all of whom have long-standing and stable supply and cooperation relationships. Our company has also strategically set up marketing and after-sales service offices in the locations of our international customers, so that we can provide the best sales and after-sales services and technical support to our existing customers, strengthen our partnership, and pursue new product opportunities, as well as effectively grasp market dynamics, develop new customers, and expand our scale of operations, making us a major niche in the industry.

5. Favorable and unfavorable factors of development prospect and countermeasures

(1) Favorable factors :

- A. According to the rapid development of information, communication and consumer electronics products, the demand for connectors/connectors is increasing and the specifications are changing from generation to generation, bringing new momentum to the market growth.
- B. Our management and R&D team have backgrounds in software, hardware design, industrial design, and institutional design, and have the necessary knowledge to build complete products. Our company has been involved in the development and design of various products to meet the demands of our customers for a long time, and we have built a complete high-frequency testing facility. We are able to develop new products in parallel with our customers in the development of high frequency transmission lines.
- C. We have production bases in Dongguan, Suzhou, Hubei Jianli and Thailand to provide production and shipping centers close to our customers, which can shorten the time of technical support, transportation and delivery, and after-sales service, and can respond to customers' demands quickly, enhancing the competitiveness of our products and services effectively. Also we have established an irreplaceable strategic partnership with our customers.
- D. We are a professional connector/connector manufacturer with more than 40 years of experience, and our technical ability has been recognized in the industry. We have been vertically integrated upstream, including the development and design of the cable and connector manufacturing, and the development and manufacturing of customer-specific cables. We have also expanded our R&D capabilities into electronic design to provide complete solutions to our customers.
- E. Our company has obtained many certifications including ISO 9001, SONY GREEN PARTNER, Samsung ECO-PARTNER, ISO 14001, and OHSAS 18001, etc. We continue to implement various quality control measures to improve the quality of our products.

(2) Unfavorable factors :

- A. The profit margin is compressed due to the high price fluctuation of raw materials and price cutting competition from the industry.
- B. Competitors in China are developing rapidly and the threat of price competition is increasing.
- C. Manufacturers generally face labor shortage and loss of R&D personnel, which affects capacity expansion and product upgrade.
- D. The scale of procurement is not large, and we do not have the advantage of scale.

(3) Countermeasures :

- A. In addition to actively improving production technology and processes, the company has strengthened cooperation with third-party companies to outsource production of low-tech or low-margin products or processes to increase production flexibility and focus manpower on the production of high-margin products or products with development benefits in response to the shortage of local labor in China.
- B. Face to the rising labor cost in China, the company continues to increase the semi-automatic production and assembly lines on the basis of the existing automation, gradually replacing some of the manpower operations and strengthening the automatic production capacity, and also continues to shift the production focus to the low labor cost factory in Thailand.
- C. Continue to develop high value-added products such as higher transmission frequency, finer pitch, and higher temperature resistance, not only to meet the demand of the existing market, but also to develop high-margin connector products for automotive, industrial computers, and medical equipment to increase gross margin and reduce the pressure of price competition in the information and communication connector market.
- D. Enhance on-the-job training for employees to improve the quality of human resources, strategic cooperation and joint design and development with customers to enhance the value of innovation, and strengthen the use of KPI, MBO and other software to improve management efficiency.
- E. Provide customers with diversified and innovative products such as USB 3.0, USB 3.1, HDMI, Thunderbolt, DisplayPort, and other high-speed transmission technology related products to keep pace with market demand and maintain revenue growth in order to expand the scale of the company's operations.
- F. Grasp the development trend of bulk materials and sign long-term supply contracts with copper suppliers in order to stabilize the source of material supply and purchase price, and continue to develop new sources of supply and seek alternative or competitively priced suppliers.
- G. Expand the market in China to serve customers nearby and actively explore low-risk pure OEM customers in China.

(2) Important applications and production process of major products

1. Important Applications of Major Products

(1) Cable/connector

Product : Computer and peripheral equipment cables/connectors, system cables/connectors for communication equipment, consumer electronics, commercial electronics, and medical equipment.

Applications : Electronic signal transmission between computers and their peripherals, consumer, server communication products, home appliances and office equipment systems.

(2) Electronic Digital Peripherals

Products : External hard disk device, external optical disk device, network hard disk, wireless storage device.

Applications : It is a computer peripheral. It is used for storage capacity expansion, backup, security devices, data sharing, and audio and video entertainment applications.

(3) Commercial Digital Peripherals

Product: smart door locks and small household appliances for daily use.

Applications: both domestic and overseas household consumer product markets beginning with an OEM business model.

2. Production Process :

Connecting cable production process 程

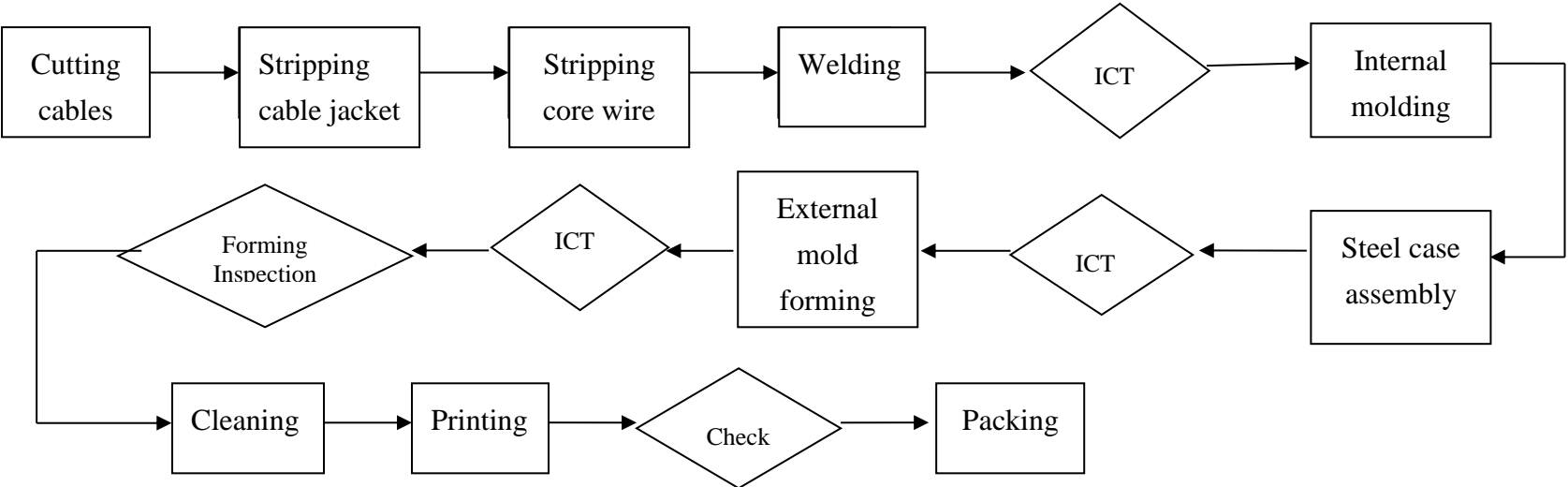

Connector Manufacturing Process

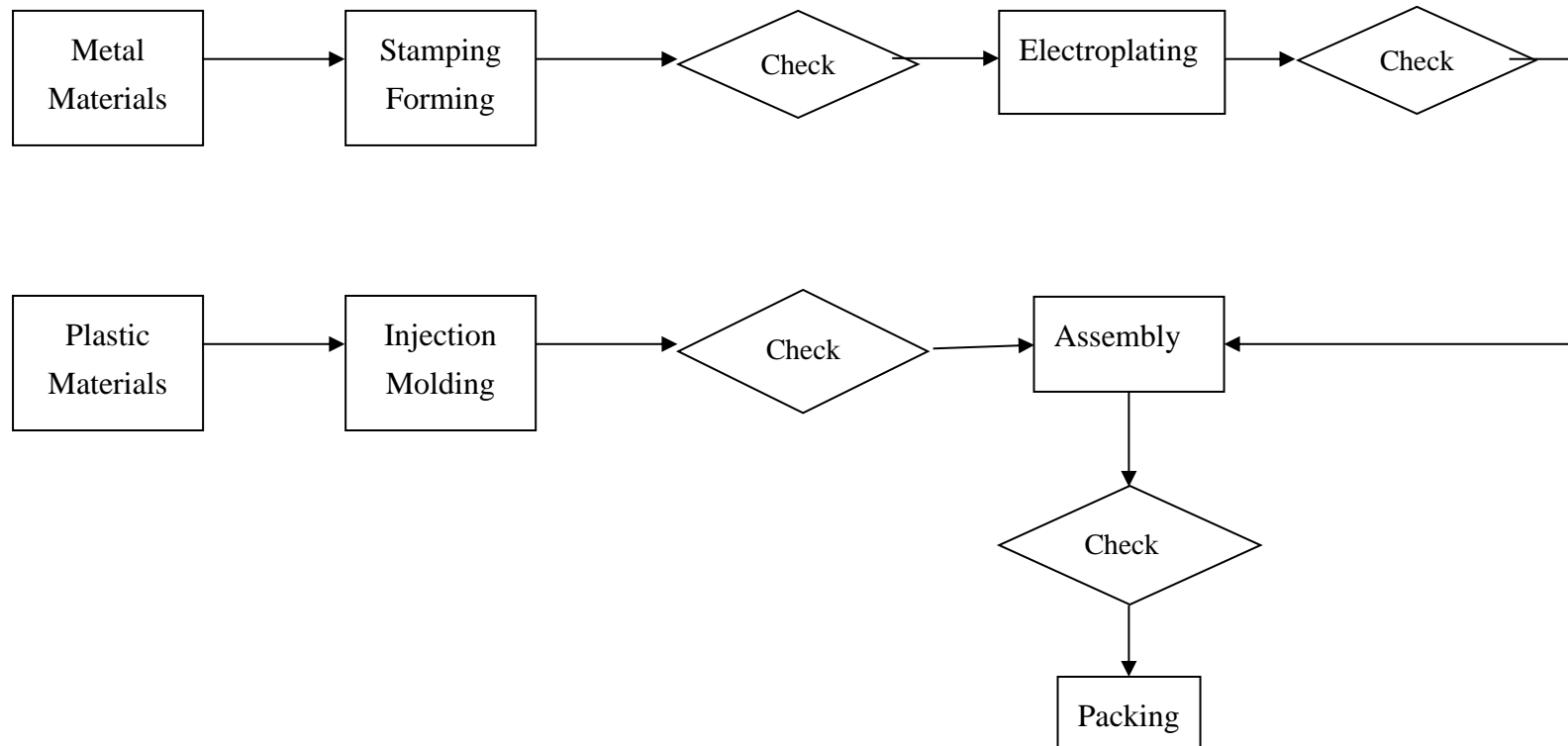

Cable Production Process

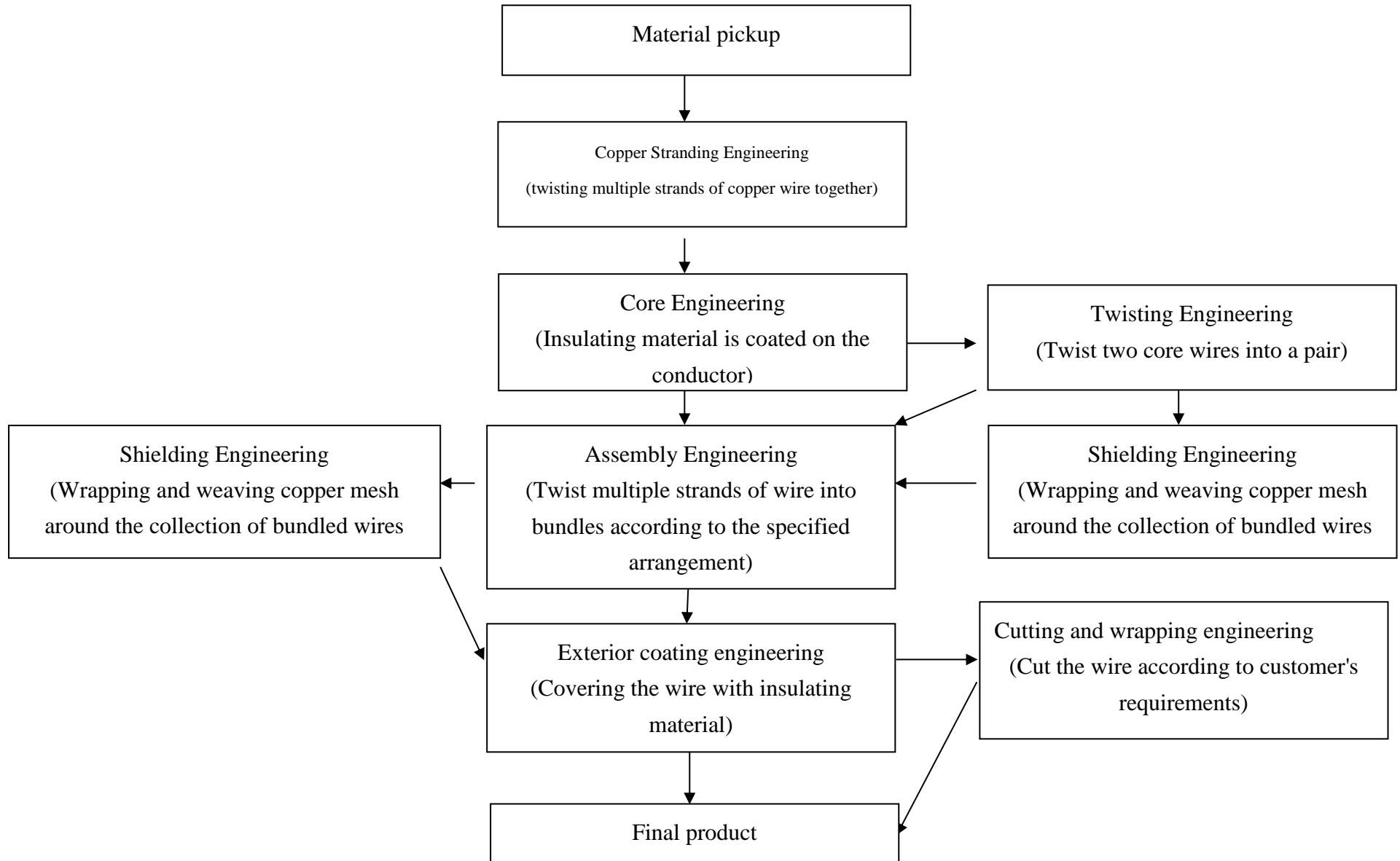

Production flow chart of electronic circuit board (PCBA)

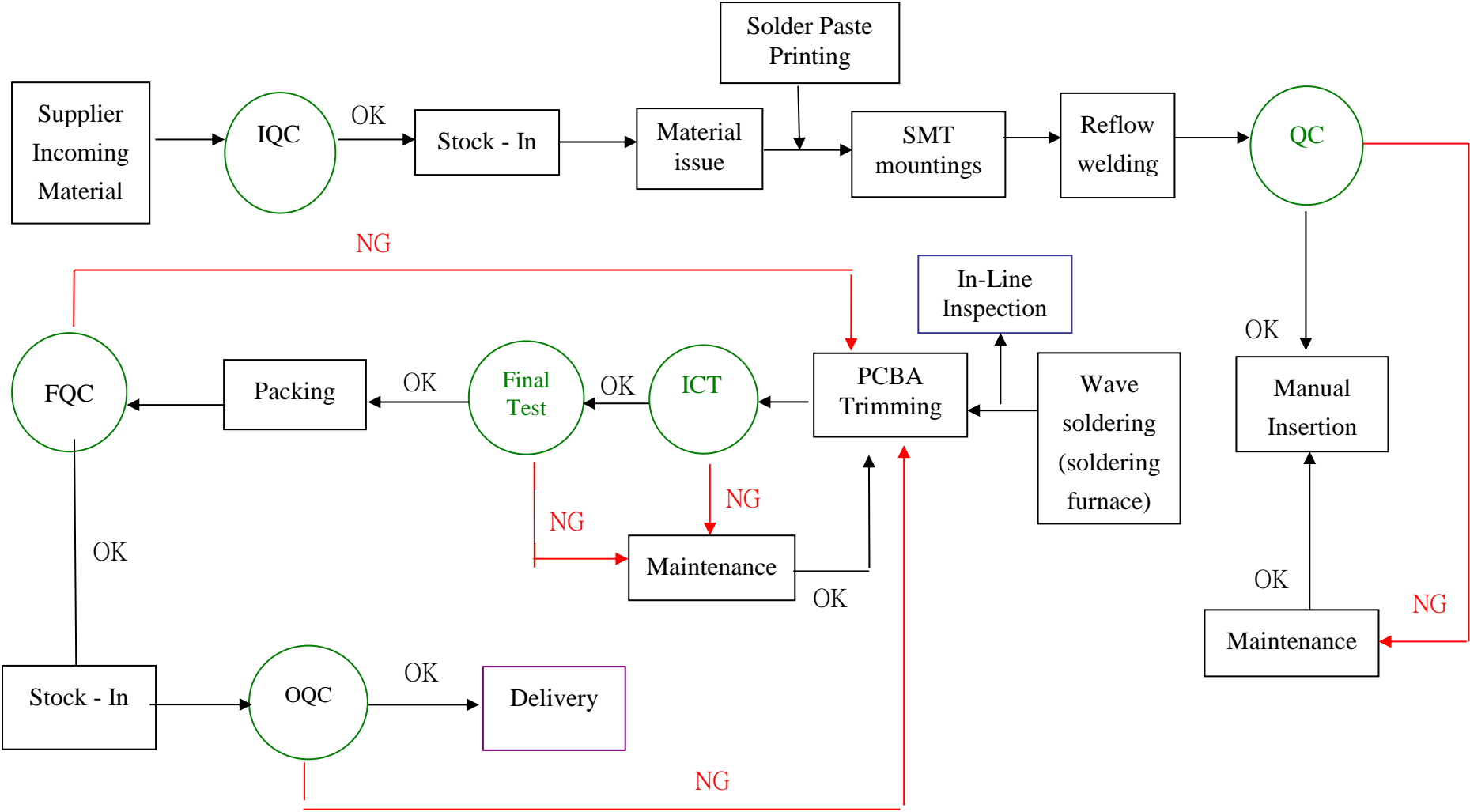

Assembly flow chart of electronic products

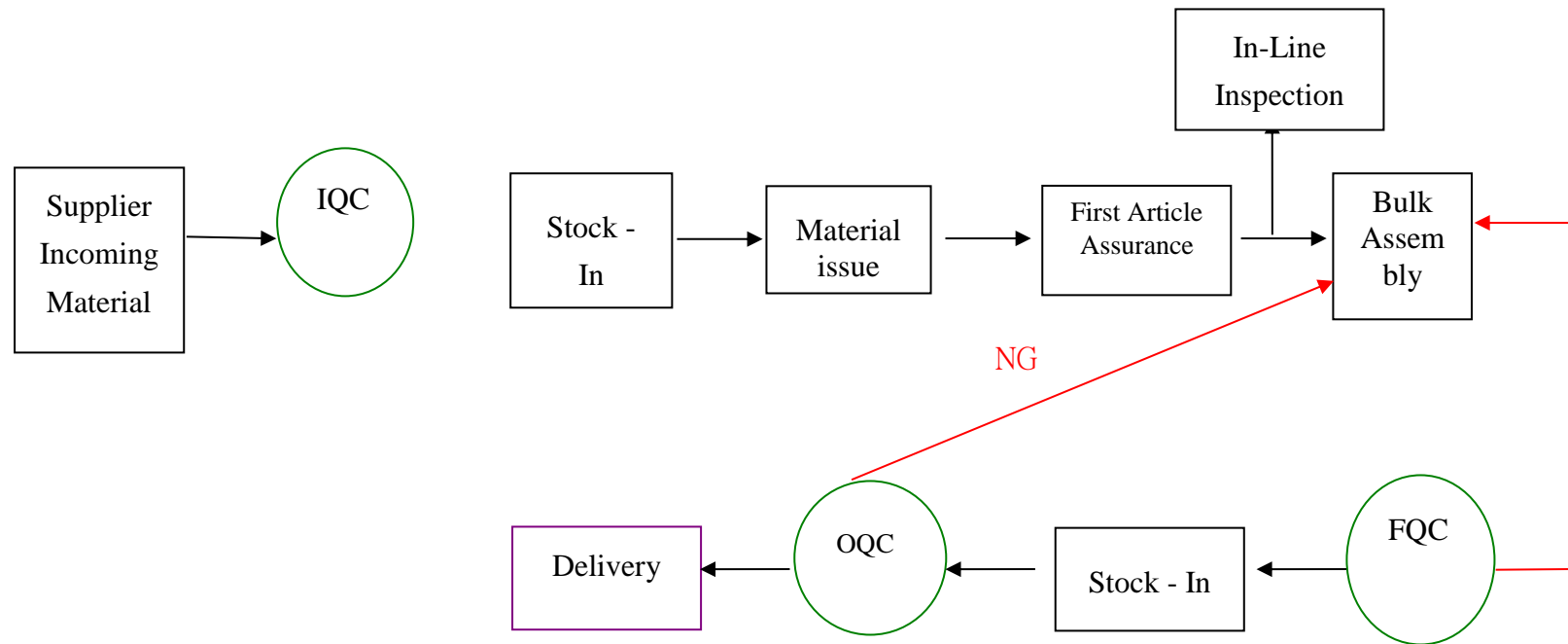

(3) Supply Status of Main Materials :

The Company's main raw materials are connectors and hard drives, etc. The main suppliers for each product category are listed below :

Product	Supplier	Status of Supply
Connector	Company A, B and D	Good
Copper Wire / Silver-Plated Hard Copper	Company C	Good

The main raw materials for our main products, including connectors and external storage devices, are supplied by our long-term partners, and the supply of raw materials is stable. We have not experienced any shortage of raw materials in the recent three years.

(4) List of major import and export customers

1. Manufacturers accounting for more than 10 percent of total imports in the most recent two years

Unit : NT\$ thousand

Item	FY 2024				FY 2025				As of the 1st quarter of FY 2026			
	Name	Amount	Percentage of Annual Net Purchases (%)	Relationship with Issuer	Name	Amount	Percentage of Annual Net Purchases	Relationship with Issuer	Name	Amount	Percentage of 1 st quarter Net Purchases	Relationship with Issuer
1	Company A	249,756	17.78%	None	Company A	325,680	19.61%	None	Company A	104,826	20.96%	None
2	Company B	148,370	10.56%	None	Company B	180,692	10.88%	None	Company C	61,020	12.20%	None
	Others	1,006,652	71.66%		Others	1,154,589	69.51%		Others	334,342	66.84%	
	Net purchase amount	1,404,778	100.00%		Net purchase amount	1,660,961	100.00%		Net purchase amount	500,188	100.00%	

Note: All of the manufacturers that accounted for more than 10% of our total purchases in the last two years are long-term partners, and there are no major abnormalities.

2. Customers who accounted for more than 10% of total sales in the most recent two years

Unit : NT\$ thousand

Item	FY 2024				FY 2025				As of the 1st quarter of FY 2026			
	Name	Amount	Percentage of Annual Net Sales (%)	Relationship with Issuer	Name	Amount	Percentage of Annual Net Sales (%)	Relationship with Issuer	Name	Amount	Percentage of 1 st quarter Net Sales(%)	Relationship with Issuer
1	Customer A	557,340	19.72%	None	Customer A	761,498	25.35	None	Customer A	232,794	29.68	None
2	Customer B	401,206	14.20%	None	Customer B	346,088	11.52	None	Customer D	105,013	13.39	None
3	Customer C	271,389	9.6%	None	Customer D	309,412	10.30	None	Customer B	86,287	11.00	None
	Others	1,596,458	56.48%		Others	1,587,393	52.83		Others	360,321	45.93	
	Net sale amount	2,826,393	100.00%		Net sale amount	3,004,391	100.00%		Net sale amount	784,415	100.00%	

Note: Customers with more than 10% of our total sales in the most recent two years are all long-term customers with no major differences.

3.Information on Employees for the Two Most Recent Fiscal Years and during the Current Fiscal Year Up to the Date of Publication of the Annual Report :

March 31, 2026

Year		FY 2024	FY 2025	As of March 31, 2026
Employees Number	Sales Staff	36	40	40
	R&D Staff	143	154	163
	Technical Staff	1,337	1,637	1,547
	Administrative Staff	410	353	345
	Total	1,926	2,184	2,095
Average age		35.94	33.00	36.80
Average years of service		5.68	3.60	5.05
Education distribution ratio	PhD	0%	0%	0%
	Master	1%	1%	1%
	College	17%	17%	16%
	High school	11%	11%	11%
	Below junior high	71%	71%	72%

4.Information on Environmental Protection Expenditure :

- (1) The total amount of losses (including compensation) and penalties suffered by the Company as a result of environmental pollution in the most recent year and up to the date of publication of the annual report, as well as its future countermeasures (including improvement measures) and possible expenses (including the estimated amount of losses, penalties and compensation that may occur if countermeasures are not taken, and if it cannot be reasonably estimated, the fact that it cannot be reasonably estimated):

1. Application for Stationary Pollution Source Installation Permit or Pollution Discharge Permit:

Name	Permit	Registration No.	Expiration
Dongguan Jian-Wei Electronics Products Co., Ltd.	Stationary Pollution Source Discharge Permit	914419006183436894001Y	2030.06.28

2. Purchase a Carbon Footprint Renewable Energy Certificate from Ecohz.
3. Subsidiary, Joinsoon Electronics Manufacturing (Thailand) Co., Ltd, purchased solar power equipment to reduce electricity usage.
4. The Company has obtained the Assurance Report for the 2024 GHG Statement.
- (2) In accordance with the EU Restriction of Hazardous Substances (ROHS) Directive: Our existing products already comply with the ROHS regulations.

5.Labor Relations

(1) Employee Benefits, Training, Education, Retirement Policy, Executions and Labor Negotiations and Measures to Protect Employee Rights.

1. Employee welfare measures, continuing education, training

(1) The Company allocates employee benefits in accordance with the relevant laws and regulations and organizes an employee benefit committee to plan, supervise and implement employee benefit matters.

(2) Labor Insurance and National Health Insurance

Our employees participate in labor insurance, national health insurance, and group life insurance and occupational hazard insurance for our employees in accordance with the law.

(3) Education Training.

A. The Company systematically provides a series of internal and external training courses for different levels of employees in general, professional and management categories. The Company held 65 training sessions in FY 2025, with a total of 1,485 hours of training and 837 participants. The training courses included executive training, general training, professional/functional training and related on-the-job training.

B. Staff Continuing Education Situation

Education Training	Internal Training	External Training
Number of trainees	805 people	32 people
Course Name	1. Training for newly trained staff 2. Internet Fundamentals Course 3. Electronic Product Development Process 4. Sustainability Report Kick-off Meeting and Training Program 5. Sustainability Report – Stakeholders and Sustainability Topics 6. Occupational Health and Safety – Healthy Workplace Lifestyle 7. Internal Control Audit Procedures and Techniques 8. Introduction to High-Speed Cable Interfaces 9. Introduction to High-Speed Testing Cables 10. Manufacturing SOP Explanation and SI Testing Procedures 11. Introduction to Power Harnesses 12. Procedures relating to the Sales Department Organization and Responsibilities Management Regulations / Customer Service Satisfaction Management Regulations / Customer Relationship Management Regulations / Customer Complaint Management Regulations 13. High-Frequency Circuit Layout / Basic Knowledge of SI Simulation Software / Product Pilot Run and Transfer to Mass Production	1. Post-U.S. Election Economic Outlook for U.S.-China Relations and Taiwan Industries. 2. Responsibility Mapping System Operations and Integrity Management. 3. Information Security Awareness, Essential Knowledge, and Responsibilities E-Course. 4. Information Security Incident Explanation and Preventive Measures E-Course. 5. Guidelines for Information Security Control in TWSE/TPEX Listed Companies E-Course. 6. Trump 2.0, the End of Globalization, and Regional Conflicts. 7. Latest Artificial Intelligence Development Trends and Practical Review of Risk Management Frameworks. 8. 2025 Cybersecurity Conference. 9. Practical Analysis of Internal Control Management for Corporate Greenhouse Gas Inventories. 10. Pre-training Program for Newly Appointed Internal Auditors. 11. Thailand, Malaysia, and the Philippines Global Supply Chain Relocation Exchange Forum. 12. Technology Forum on the

	<ul style="list-style-type: none"> 14. Company Introduction and Computex Training 15. JEM Sales Department Roles and Responsibilities Management Regulations 16. Introduction to Corresponding Contact Windows at Each Plant 17. ERP, ESP, and BPM Operating Procedures 18. Introduction to New Product – Thunderbolt 5 Cable 19. Basic Knowledge of 2D/3D Drawing and Product Manufacturing Processes / Product Pilot Run and Transfer to Mass Production 20. Introduction to Latest Environmental Regulations (SONY SS00259 Version 23) 21. Corporate Philosophy– 22. Promotion of Good Leadership and Employee Conduct 23. Introduction to Internal Audit Department Functions and Internal Control; Corporate Governance Operations Promotion; Internal Audit Training 24. Antenna Design Verification Procedures 25. Introduction to Antenna Products 26. Introduction to In-flight Cable Products 27. Corporate Social Responsibility (Integrity Management – Whistleblowing and Complaint Mechanisms, Gender Equality, and Sexual Harassment Prevention) 28. Introduction to Quality Assurance and Customer Complaints Handling 29. Introduction to External Cable Products 30. Introduction to JEM Electronic Products 31. Fraudulent Conduct Reporting Management 32. Material Information Handling Procedures and Insider Trading Prevention Management 33. Occupational Health and Safety Training Program 34. Introduction to Internal BPM Forms (General Purpose) 35. JEM Company Introduction and Roadmap Overview 36. ERP System Training 37. Introduction to Information Services and Information Security 38. ESP Training Course 39. KM System Education and Training 40. International Trade Terms Training Program 41. AI Server Cable Training 	<p>Connector Industry under Rapid Transformation.</p> <ul style="list-style-type: none"> 13. Trends and Current Status of Employee Welfare Trust Development. 14. 2025 Greenhouse Gas Inventory Practical Promotion Seminar. 15. Talent and Organizational Transformation Trend Exchange Forum – “Make Taiwan Great Again”: Transforming MAGA Challenges into Opportunities for Corporate Global Competitiveness. 16. “Human-Machine Collaboration Is No Longer a Dream!” – How Robotic Process Automation (RPA) Can Enhance Internal Control Effectiveness.
--	---	--

	42. USB 3.1 and USB 3.1 Type-C Basic / Intermediate / Advanced Knowledge and Market Conditions 43. TCO Certified Training 44. BPM Digitalization – Credit Line Application Procedures 45. Basic Knowledge of Server Cables, Automotive Wire Harnesses, In-flight Cables, or Connectors / Product Pilot Run and Transfer to Mass Production 46. Professional Engineering Expertise, Project Scheduling Allocation, and Management Knowledge 47. Product Application Knowledge / Customer Specification Confirmation and Abnormal Issue Communication 48. IATF 16949:2016 and ISO 9001:2015 Internal Auditor Training 49. Thunderbolt Cable Certification, Cable Standards, and Cable Quotation Training	
--	---	--

2. The retirement system and its implementation status

In accordance with the Labor Standards Law, the Company has established a retirement plan for its employees and contributes monthly to a retirement reserve based on total salary to be deposited into a pension account at the Bank of Taiwan. The Company may choose to apply the pension provisions of the Labor Standards Law or the pension system of the Labor Standards Law and retain the years of service prior to the application of the Labor Standards Law. For employees subject to the Act, the Company's monthly contribution rate to the employees' pension fund shall be 6% of the employees' monthly salary.

3. Status of labor-management agreements and various measures to protect employees' rights and interests

Our company belongs to the labor standard law applicable industry, and all operations are in accordance with the labor standard law, and we uphold the concept of integration of labor and management. We hold monthly meetings with our employees and through the meetings with the supervisors of each unit, and hold Management and Labor Council quarterly to facilitate the communication between employers and employees. Up to now, there has been no labor dispute and both employers and employees work together for professional development and labor welfare to create a win-win situation.

4. Work environment and employee safety protection measures

- (1) The office environment of our company is designed to protect the safety of our employees, to ensure that staff are given maximum protection at work. Access control and video recording devices are installed at entrances and exits to ensure the safety of employees.
- (2) All electrical and mechanical equipment (such as fire alarms and fire extinguishers) are regularly maintained or repaired according to their prescribed schedules to ensure that they are in the best working condition at all times.
- (3) The management committee of the park where the Company is located was awarded the “Excellent Covid-19 Prevention Community Award” by New Taipei City in 2020 and the “Excellent Fire Prevention Measures Facility” by the National Fire Agency, Ministry of the Interior in 2018.
- (4) We promotes occupational safety and health management and has had the occupational safety and health affairs managers since 2021, with the goal of creating the best working environment for all employees with zero injuries, zero occupational diseases, and zero accidents.

- (5) We conduct regular annual health checkups for our employees so that they can have a proper understanding of their health, and we also carry out group insurance for our employees to increase their protection at work.
- (6) During the period of influenza, we carried out environmental disinfection operations from time to time, and discusses and promotes relevant measures in the monthly meeting to create a safe and healthy working environment for employees.
- (7) We regularly convene management and labor council and coordinate labor relations with both employers and employees to promote labor-management cooperation.
- (8) The office area is designed as a comfortable open space, and has a nursing room for female colleagues, creating a friendly and healthy workplace.
- (9) Smoking is prohibited in offices, but there are "smoking areas" in appropriate locations in the park where smokers can smoke. Appropriate separation of smoking and non-smoking areas protects the health of non-smokers, and respects smokers by providing appropriate places to smoke.
- (10) With regard to occupational health, we conduct physical and chemical hazardous characteristics of each unit in accordance with the annual safety and health management plan, and conducts carbon dioxide environmental monitoring every six months to comply with legal requirements.
- (11) The annual education and training provides internal and external training seminars and courses for employees to promote self-improvement, achieve personal career development, and jointly strengthen the professionalism and healthy workplace.

5. Employee code of ethics and conduct

The Company has established "Work Rules" and "Staff Rules" for all employees to understand employee behavior, conduct and ethics, so that the Company's management and all employees can follow them, and They are announced on the Company's intranet bulletin area for all employees to check at any time, as well as the relevant rules and regulations are briefly described as follows :

- (1) Based on professional ethics and respect for others, colleagues should not read any files on other people's desks or in the data cabinet without the consent of the person concerned or due to urgent business needs.
- (2) Department heads should supervise their staff to keep important information that affects the company, such as customer transactions, product prices, technical secrets, etc., confidential.
- (3) Disposal of documents or data shall be done by shredder or other appropriate means after submitting to the immediate supervisor for approval, and shall not be disposed of arbitrarily.
- (4) The company will dismiss the employee who steals the company's confidential business documents to a third party through the Internet or improper means, causing significant damage to the company, and reserves the right to claim compensation and all other rights.
- (5) During the term of the employment contract, an employee shall not, without the written consent of the Company, do any of the following:
 - A. Invest in the same or similar business as the Company's business in his/her own name or in the name of others. However, the Company shall not invest in publicly traded stocks through a stock exchange institution if the total shareholding is not sufficient to affect the operation of each company in which the Company invests.
 - B. To act as an employee, appointee or consultant of a company whose business is the same as or similar to the Company's.
- (6) All new employees, regardless of their rank, shall sign an employment contract, an "Integrity and Confidentiality and Intellectual Property Agreement", an "Internal Material Information Confidentiality Agreement", a "Competitive Terms and Conditions/Confidentiality Agreement" and an "Integrity and Confidentiality Pledge" on the date of their employment.

- (2) The losses suffered by the Company as a result of labor disputes in the most recent year and up to the date of publication of the annual report, and the estimated amount of current and potential future losses and countermeasures :

The Company has good labor relations and has not suffered any losses due to disputes.

6.Cyber Security Management

- (1) Describe the cyber security risk management framework, cyber security policies, concrete management programs, and investments in resources for cyber security management :

1. Promoted Management Issues and Specific Management Plan: Enhancement of information security defense capability: Conduct regular vulnerability analysis and penetration testing of the information security system, as well as enhance and repair system to reduce the risk of information security. Establish a contingency plan for network security incidents, assess the impact and loss according to the severity of the incident, and take corresponding report and recovery actions.

2. Cyber Security Implementation

- (1) Send e-mail or conduct information security awareness promotion at monthly meetings to enhance employees' information security awareness, and urge managements to strengthen the information security awareness of their colleagues.
- (2) Information security education and training and new staff safety training.
- (3) Monitor other company's information security incident response and manage information security cases.
- (4) Software inventory to ensure using legally licensed software and to prevent illegal software.
- (5) Enhance network visibility, monitor network traffic, centralize storage of Logs, and timely report abnormal events.
- (6) Install firewalls and anti-virus software, and regular update virus codes to enhance network security protection.
- (7) KPMG conducted an information cycle audit in April 2025 and concluded that there were no circumstances involving significant direct or immediate cybersecurity risks.

- (2) The Company shall state the losses, possible impacts and responses to major information security incidents suffered in the most recent year and as of the publication date of the annual report, and if it cannot be reasonably estimated, the fact that it cannot be reasonably estimated: None.

7.Important Contracts

Nature of Contract	Parties	Contract Commencement and Expiration Dates	Main content	Restrictive Claus
Bank Financing Contracts	Mega International Commercial Bank Co., Ltd.	May 25, 2023 ~ May 25, 2030	Medium-term guarantee loans	None
Rental Contract	Dongguan Yinshida Trading Company Limited	March 1, 2025 ~ February 28, 2030	Factory rental	None

V. Financial Status and Financial Performance Review

Analysis and Risk Issues

1. Financial Status

The main reasons for the significant changes in assets, liabilities and equity in the most recent two years and a comparative analysis of their effects :

Unit : NT\$ thousand

Item \ Year	FY 2024	FY 2025	Difference		
			Amount	%	Change Analysis (Note)
Current Assets	1,669,778	1,698,344	28,566	1.71	
Non-current assets	1,710,005	1,890,204	180,199	10.54	
Total Assets	3,379,783	3,588,548	208,765	6.18	
Current Liabilities	1,107,294	1,522,793	415,499	37.52	1
Non-current Liabilities	637,877	506,583	(131,294)	(20.58)	2
Total Liabilities	1,745,171	2,029,376	284,205	16.29	
Capital stock	1,215,822	1,215,822	0	-	
Capital Surplus	238,560	238,560	0	-	
Legal reserve	38,261	38,261	0	-	
Special reserve	29,352	0	(29,352)	(100.00)	3
Retained earnings	58,705	(26,831)	(85,536)	(145.70)	4
Other Equity	53,877	93,360	39,483	73.28	5
Non-controlling interests	35	0	(35)	(100.00)	
Total Equity	1,634,612	1,559,172	(75,440)	(4.62)	

Note: If the percentage of change does not reach 20% and the amount does not reach NT\$10 million, no analysis will be made.

Description:

1. Current liabilities: Mainly due to the significant increase in short-term loans, accounts notes and payable.
2. Non-current liabilities: Mainly due to the issuance of the fifth domestic unsecured convertible bonds reclassified as “corporate bonds maturing in one year or one fiscal year, or for which a put option has been exercised”.
3. Special surplus reserve: Mainly due to the reversal of special surplus reserve for the period.
4. Retained earnings: Mainly due to the loss in 2025.
5. Other equity: Mainly due to the exchange differences resulting from translating the financial statements of foreign operations.

2. Financial Performance

The main reasons for the significant changes in operating revenues, net operating income and profit for the last two years and a comparative analysis of their operating results :

Unit : NT\$ thousand

Item	Year		Increase (decrease) Amount	Change ratio (%)	Descripti on of change
	FY 2024	FY 2025			
Sales revenue	2,826,393	3,004,391	177,998	6.30	
Cost of sales	2,409,412	2,591,083	181,671	7.54	
Gross Profit	416,981	413,308	(3,673)	(0.88)	
Operating Expenses	571,881	519,952	(51,929)	(9.08)	
Net operating loss	(154,900)	(106,644)	48,256	(31.15)	1
Non-operating income and expenses	69,068	(17,915)	(86,983)	(125.94)	2
Loss before tax	(85,832)	(124,559)	(38,727)	45.12	2
Income tax expense	8,304	(7,829)	(16,133)	(194.28)	3
Loss	(94,136)	(116,730)	(22,594)	24.00	2
Other comprehensive income (loss)	84,105	41,470	(42,635)	(50.69)	4
Comprehensive income	(10,031)	(75,260)	(65,229)	650.27	5

Note: If the percentage of change does not reach 20% and the amount does not reach NT\$10 million, no analysis will be made.

Description: :

1. Net operating loss: Mainly due to the decrease in research and development expense, the operating loss decreased.
2. Non-operating income and expenses: Mainly due to the appreciation of the NTD/USD exchange rate in 2025, which resulted in an increase in net foreign currency exchange losses.
3. Income tax expense: Mainly due to the adjustment of deferred tax liabilities.
4. Other comprehensive income (loss): Mainly due to the loss on exchange differences arising from the translation of the financial statements of foreign operating companies as a result of the evaluation of the conversion to investment at the end of the year.
5. Comprehensive income: Mainly due to the increase in loss for the period.

3. Cash Flow

(1) An analysis of the changes in cash flows for the most recent two years is described below.

Unit : NT\$ thousand

Item	FY 2024	FY 2025	Increase (decrease) Amount	Change ratio (%)
Operating Activities	(45,105)	139,619	184,724	(409.54)
Investing Activities	(255,654)	(195,348)	60,306	(23.59)
Financing activities	215,436	26,788	(188,648)	(87.57)
Effect of exchange rate changes on cash and cash equivalents	(6,450)	(22,989)	(16,539)	256.42
Total	(91,773)	(51,930)	39,843	(43.41)

Analysis of changes in cash flows:

1. Net cash inflow from operating activities increased by \$184,724 thousand, mainly due to the increase in notes and accounts payable in 2025.
2. Net cash outflow from investing activities increased by \$60,306 thousand, mainly due to the decrease in cash outflow from the acquisition of property, plant and equipment in FY 2025 compared to the previous period.
3. Net cash inflow from financing activities decreased by \$188,648 thousand, mainly due to the cash capital increase from last period and the repayment of corporate bonds.
4. As mentioned above, the net cash outflow from financing activities decreased by \$39,843 thousand in FY 2025 compared to FY 2024.

(2) Improvement plan for lack of liquidity: Not applicable

(3) Cash flow analysis for the coming year

Unit : NT\$ thousand

Cash balance at the beginning (Note)	Net cash flows from operating activities of the year	Cash (inflow) volume of the year	Amount of cash surplus (short)	Remedy for projected cash short	
				Investment plan	Financing Plan
224,676	95,494	134,208	358,884	—	—

Note: Cash balance includes cash and bank deposits.

1) Analysis of changes in cash flows for the coming year (2026):

- (1) Operating activities: Mainly due to the expected inflow of operating activities in the coming years.
- (2) Investing activities: Mainly due to the cash outflow such as estimated acquisition of property, plant and equipment, research and development equipment, and investment software of approximately NT\$150,000 thousand.
- (3) Financing activities: It is expected to increase cash capital NT\$170,800 thousand to repay the loans and the principal of lease liabilities.

4. Effect of significant capital expenditures on financial operations in the most recent year: None

5. The most recent annual reinvestment policy, the main reasons for its profit or loss, improvement plans and investment plans for the coming year :

(1) The reinvestment policy in the most recent year :

The Company's business management policy for its investee companies is based on the "Investment Cycle", "Procedures for Transactions with Related Parties, Specified Companies and Group Enterprises", "Regulations for Supervision and Management of Subsidiaries" and "Procedures for the Acquisition or Disposal of Assets" of the internal control system, which serve as the guidelines for the operation and management of the investee companies. In addition, the Company's internal auditors regularly review the operating status and internal controls of each investee company to facilitate the management of the investee company and to enable the Company to effectively control the operation of each investee company.

(2) Main reasons for profit or loss on reinvestment and improvement plans :

December 31, 2025; unit: NT\$ thousand

Item / Description	Investment amount	Policy	Main Reasons for Profit or Loss	Investment (loss) income	Improvement Plan
Conquest (BVI) and its subsidiaries	323,663	Vertical production integration of upstream and downstream industries	Due to loss of a reinvested company, Jianwei Electronics received.	(46,289)	Develop business aggressively Reduce operating costs
Teamplus Technology Inc	21,034	Expanding into different business areas	Due to the increase in SMS traffic costs.	(4,238)	Develop business aggressively
Evergrand and its subsidiaries	91,616	Vertical production integration of upstream and downstream industries	As a result of the loss from the reinvestment in the subsidiary.	(39,346)	Develop business aggressively Reduce operating costs
Joinsoon Electronics Mfg. Co., (Thailand) Ltd.	975,941	Vertical production integration of upstream and downstream industries	Mainly due to the expansion of the production capacity and the increase in revenue.	31,855	
Volex-JEM Co., Ltd	17,752		The dissolution has completed in October 2025.	(3)	—

(3) Investment plan for the coming year: Investment of approximately \$49 million in machinery and equipment.

6. Risk analysis and evaluation

(1) Risk Management Policy :

The Company has been established for more than 40 years and has experienced the economic cycle for many years. In the light of the principle of professional division of labor, the specialized departments are responsible for evaluating and implementing strategies to address various risks.

Except for the professional evaluation of market risk, strategy and operational risk, we also hold regular "Management Meeting" to evaluate the overall impact and decide the overall response strategy through discussion.

The financial risk, liquidity risk and credit risk are evaluated and responded to by the finance staff on a regular and irregular basis, focusing on the current situation and the short and long term future, and the formulation of response plans.

(2) Organizational structure of risk management. :

Management Meeting: To coordinate the overall risk management of the company.

All business divisions: Evaluate and respond to market risks.

Finance Division: Evaluate and respond to financial risk, liquidity risk, and legal risk.

(3) The impact of changes in interest rates, exchange rates and inflation on the Company's profit or loss and future countermeasures. :

1. Effect of interest rate changes on the Company's profit or loss and future countermeasures :

(1). Effect of interest rate changes on the Company's profit or loss and future countermeasures

A. Effect on the Company's profit or loss :

Unit : NT\$ thousand

ITEM	FY 2024		FY 2025	
	Amount	Ratio of net revenue	Amount	Ratio of net revenue
Interest expense	21,238	0.75%	30,502	1.02%

The interest expense was \$21,238 thousand and \$30,502 thousand for fiscal 2024 and 2025, respectively, which accounted for 0.72% and 1.02% of the net operating revenues for each year. The interest expenses accounted for only a small percentage of the Company's operating income, so the change in interest rates did not have a significant impact on the Company.

B. Countermeasures :

In accordance with the changes in interest rates, the Company will maintain good relationships with its banks and regularly evaluate the trend of interest rates in order to obtain more favorable interest rates and reduce interest expenses as the Company's operations expand and its demand for bank capital increases. If necessary, we will raise capital to increase our own capital ratio or obtain more favorable financing costs in order to reduce the impact of interest rate changes on the Company's profit and loss. °

2. Effect of exchange rate changes on the Company's profit or loss and future countermeasures. :

(1) Effect on the Company's profit or loss :

Unit : NT\$ thousand

ITEM	FY 2024		FY 2025	
	Amount	Ratio of net revenue	Amount	Ratio of net revenue
Exchange (Loss)	67,672	2.39%	(1,762)	(0.06%)

The net exchange gain or loss for 2024 and 2025 were \$67,672 thousand and \$(1,762) thousand, respectively, which accounted for 2.39% and (0.06%) of the net operating revenues for the years, respectively, and represented a small percentage of the operating revenues.

(2)Countermeasures

Over 90% of the Company's revenue is derived from foreign sales (mainly denominated and received in U.S. dollars), and the purchase cost of raw materials is also mainly for foreign purchases. In order to reduce and avoid foreign exchange losses on foreign currency conversion to NTD, the Company will take the following countermeasures: :

- (1) Foreign currency debts and liabilities are offset against each other to produce a natural hedging effect.
- (2) The Company has a defined foreign exchange hedging policy and uses forward exchange contracts and foreign exchange swap contracts to reduce the exchange rate risk arising from foreign currency assets and liabilities.
- (3) The Company pays for equipment and raw materials in foreign currencies to naturally hedge the exchange rate risk of major currencies.
- (4) In view of future revenue growth, the Company may also operate short-term foreign currency borrowings as a hedging instrument.

3. Impact of inflation on the Company's profit and loss and future measures :

(1) Effect on the Company's profit or loss :

The Company has not experienced any significant impact on its financial operations due to inflation to date.

(2) Countermeasures :

In order to maintain stable supply prices, the Company keeps abreast of global political and economic changes and market price movements, maintains good interaction with suppliers and customers, and adjusts its purchasing and sales strategies in a timely manner, so that the Company can respond to the impact of future changes in economic conditions, such as inflation, without suffering a significant impact on its operations.

(4) The Company's policies for engaging in high-risk, highly leveraged investments, lending of funds to others, endorsement of guarantees and derivative transactions, the main reasons for profits or losses, and future countermeasures :

1. Engaged in high-risk, highly leveraged investments: None.

2. Loans of funds and endorsement guarantees: The Company has endorsed and guaranteed to its subsidiaries for the most recent year and up to the date of the publication of the prospectus, and the endorsement and guarantee are for the purpose of operational needs and in accordance with the 'Procedures for Lending Funds to Other Parties'. In addition, the Company has endorsed and guaranteed to its subsidiaries for the most recent year and up to the date of the publication of the prospectus, and the endorsement and guarantee are for the purpose of operational needs and in accordance with the 'Procedures for the Handling of Endorsement and Guarantee'.

3. Derivative transactions: The purpose of the derivative transactions is to hedge the exchange rate risk arising from business operations, and they are handled in accordance with the "Procedures for Handling Derivative Transactions".

In summary, the Company does not engage in high-risk investment activities to ensure the safety of its assets and therefore has no significant profit or loss.

(5) Future research and development plans and estimated investment in R&D expenses :

R&D Project Name	Project Description	Estimated Development Timeline	Estimated R&D Costs
USB-C PFAS alternative material solutions	In response to the requirements of the EU PFAS	Development in early 2025 for 2 years	Approx. NT\$2 million
GEN-Z 1C(56pin) Series GEN-Z 2C(84pin) Series GEN-Z 4C(140pin) Series GEN-Z 4C(168pin) Series	requirements of the EU PFAS. Server Series Cable	Development in 4th quarter of 2025 for 2 years	Approx. NT\$5 million

(6) The impact of significant domestic and foreign policy and legal changes on the Company's financial operations and countermeasures :

The Company always pays close attention to domestic and foreign political and economic developments and changes in laws and regulations and responds to them appropriately and in a timely manner. As of the printing date of the Prospectus, there have been no significant changes in domestic or foreign policies and laws that have had a significant impact on the Company's finances and operations. The Company will continue to pay close attention to any changes in policies and laws that may have a material impact on the Company's finances and operations. In addition, the Company will continue to pay close attention to regulatory and policy developments in various regional markets, and continue to enhance its production processes, improve quality control and strengthen upstream and downstream relationships in order to provide a more flexible supply chain to provide products that meet customers' needs and to enable the Company to continue to make profits.

(7) The impact of technological changes (including information and communications security risks) and industry changes on the Company's financial operations and countermeasures :

The Company pays attention to the policy development of the industries it operates in and the changes in the market supply and demand environment, collects relevant market research information to grasp the market trend, adjusts its business strategy and product portfolio in a timely manner to ensure its competitive advantage in the market, and actively expands future market applications and continues to reduce production costs to reduce the impact of technological changes and industry changes on the Company.

Regarding information security, the Company actively builds multi-layer information security protection and continues to improve its information security system to ensure that the computer systems of the Company's operations, accounting and other important functions are protected from operational risks due to cyber attacks. When there is a significant domestic or international information security incident, we will strengthen the monitoring of suspicious internal and external access behaviours. Regularly back up system data and files to ensure uninterrupted system operations. Promote information security information to enhance employees' awareness of information security, and prohibit the private download and use of computer programmes outside the company's business purposes or the use of other computer programmes from unknown sources to avoid creating cybersecurity loopholes.

- (8) The impact of corporate image change on corporate crisis management and countermeasures :

The Company has always taken "excellence and service first" as its corporate core spirit, complied with relevant laws and regulations, and actively strengthened internal management and improved management quality and performance in order to continuously maintain an excellent corporate image and increase customers' trust in the Company. As of the date of publication of the Company's latest annual report and the date of publication of the Company's public statement, there has been no incident that may affect the Company's corporate image. In addition, the Company will continue to implement various corporate governance requirements in order to reduce the occurrence of corporate risks and their impact on the Company.

- (9) Expected benefits, possible risks and countermeasures of mergers and acquisitions: The Company has no plans to conduct mergers and acquisitions.

- (10) Expected benefits, possible risks and countermeasures for plant expansion :

The Company will increase the production capacity of its Thailand plant in response to the development trend of the regional economy and the needs of its customers. The Company will conduct prudent and prudent efficiency assessment for the expansion plan, and will also strengthen internal management and enhance production line performance after the expansion to increase profitability.

- (11) Risks associated with the concentration of imports or sales and countermeasures :

- (1) Import

The Company's largest single supplier accounted for 17.78% and 19.61% of net purchases in FY 2024 and FY 2025, respectively. The Company's suppliers are still diversified, and there is no risk of concentration of imports to the Company.

- (2) Sales

The Company's largest single customer accounted for 19.72% and 25.35% of net sales in FY 2024 and FY 2025, respectively. The Company will continue to actively explore new customers and new business opportunities to reduce the risk of concentration of sales, as well as maintaining good relationships with its current customers.

- (12) The impact, risk and response measures on the Company due to the substantial transfer or replacement of the shareholding of directors, supervisors or major shareholders holding more than 10% of the shares: None.

- (13) Effect of change in operating right, risk and response: The Company did not have any risk of change in operating right from FY 2025 to the publication date of the annual report.

- (14) For litigation or non-litigation events, the Company and its directors, supervisors, general manager, persons in charge, major shareholders holding more than 10% of the shares, and affiliated companies should disclose the facts of the dispute, the amount of the subject matter, the commencement date of the litigation, the main parties involved in the litigation, and the disposition of the case as of the printing date of the annual report: Not applicable.

- (15) Other significant risks and countermeasures: None.

7. Other important matters: None.

VI.Special Disclosure

1.Information on Affiliates Companies :

(1) Overview of Affiliate Companies

1. Affiliated Company Chart :

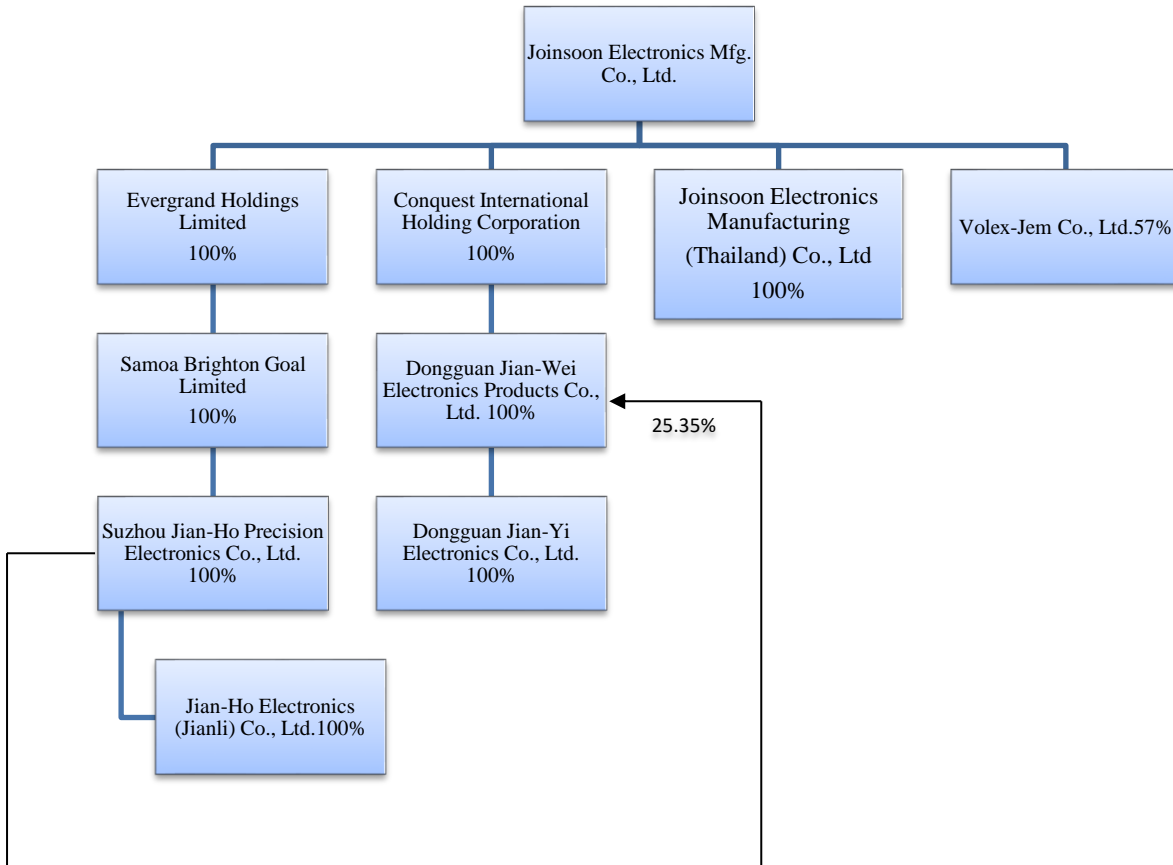

2. According to Article 369-3 of the Company Act, a subordinate company is presumed to have a controlling and subordinate relationship: None.

3. According to Article 369-2, Paragraph 2 of the Company Act, the Company directly or indirectly controls the personnel, financial or business operations of the subsidiaries: None.

(2) Basic information of each affiliated company

December 31, 2025; Unit: NT\$ thousand

Company Name	Date of Incorporation	Address	Paid-in capital	Main business or production items
Conquest International Holding Corporation	October 1992	P.O.BOX957,Offshore Incorporations Centre ,Road Town, Tortola ,British Virgin Isalands	NTD 323,663	Investment Holdings
Evergrand Holdings Limited	January 2004	Offshore Chambers, P.O. Box217,Apia, Samoa	USD3,000 Equivalent to NT\$90,630	Investment Holdings
Samoa Brighton Goal Limited	January 2002	Offshore Chambers, P.O. Box217,Apia, Samoa	USD3,000 Equivalent to NT\$94,170	Investment Holdings
Joinsoon Electronics Manufacturing (Thailand) Co., Ltd	September 2012	68 Moo 18, Suwintawong Rd., Saladaeng, Bangnumpriew, Chachoengsao, 24000 Thailand	THB 1,082,619 Equivalent to NT\$975,941	Mainly produces wire bonded products (including connectors)
Dongguan Jian-Wei Electronics Products Co., Ltd.	October 1992	Jinqiao Industrial Zone, Qingxi Town, Dongguan City, China	RMB103,463 Equivalent to NT\$431,664	Mainly produces wire bonded products (including connectors)
Dongguan Jian-Yi Electronics Co., Ltd.	June 2012	Jinqiao Industrial Zone, Qingxi Town, Dongguan City, China	RMB6,000 Equivalent to NT\$29,520	Processing and manufacturing of computer peripheral products
Suzhou Jian-Ho Precision Electronics o., Ltd.	September 2004	Weitang Town, Xiangcheng District, Suzhou, Jiangsu Province, China	USD3,000 Equivalent to NT\$94,170	Mainly produces wire bonded products (including connectors)
Volex-Jem Co., Ltd. (Note 2)	August 2016	19F.-13, No. 79, Sec. 1, Xintai 5th Rd., Xizhi Dist., New Taipei City, Taiwan	NTD31,144	Investment holding
Jian-Ho Electronics (Jianli) Co., Ltd.	May 2024	No. 6, Garment Industrial Park, Guanli City, Jingzhou, Hubei Province, China	RMB2,000 Equivalent to NT\$9,048	Mainly produces wire bonded products (including connectors)

Note 1: If the affiliated company is a foreign company, the name and address are in English, and the paid-in capital is expressed in foreign currency, with the amount converted to Taiwan dollars on the reporting date.

Note 2: The liquidation the Volex JEM was completed on October 2025.

(3) Information on the same shareholders who are presumed to be in a controlling and subordinate relationship: None.

(4) Industries covered by the overall business of the affiliate :

1. The businesses of the Company and its affiliates include wire bonded products (including connectors), and investment holding.
2. Business interactions and division of labor among related companies: The Company entrusts the production of raw materials to Suzhou Jianhe Precision Electronics Co., Ltd. The raw materials are supplied by the Company or entrusted to these companies, and the finished products are bought back through triangular trading.

(5) Information on directors, supervisors and general managers of affiliated companies :

December 31, 2025; Unit: NT\$ thousand

Company Name	Title	Name or representative	Number of shares held	
			Number of Shares / Capital Contribution	Shareholding %
Conquest International Holding Corporation	Director	Representative of Joinsoon Electronics Mfg. Co., Ltd.: Huang, Chin-Hsiung	10,128	100
Evergrand Holdings Limited	Director	Representative of Joinsoon Electronics Mfg. Co., Ltd.: Huang, Chin-Chi	3,000	100
Samoa Brighton Goal Limited	Director	Evergrand Holdings Limited	3,000	100
Joinsoon Electronics Manufacturing (Thailand) Co., Ltd	Director	Representative of Joinsoon Electronics Mfg. Co., Ltd.: Huang, Chin-Hsiung	10,826	100
		Representative of Joinsoon Electronics Mfg. Co., Ltd.: Huang, Chin-Chi		
		Representative of Joinsoon Electronics Mfg. Co., Ltd.: Au, Keng-Hung		
Dongguan Jian-Wei Electronics Products Co.,Ltd..	Directors	Huang, Chin-Chi Chiu, Li-Yueh Lo, Jung-Tsang	431,664	100 (Contribution ratio))
	Supervisor	Ou, Keng-Hung		
Dongguan Jian-Yi Electronics Co., Ltd.	Legal Representative	Huang, Chin-Chi	29,520	100 (Contribution ratio))
	Supervisor	Li, Hsiu-Mei		
Suzhou Jian-Ho Precision Electronics Co., Ltd.	Director	Lo, Jung-Tsang	94,170	100 (Contribution ratio)
		Lin, Chien-Huang		
		Liu, Yung-Tsan		
Volex-Jem Co., Ltd. (Note)	Director	Lin, Wu-Chi	1,775	57
		Huang, Chin-Chi	1,339	43
		Liu, Ning	-	-
	Supervisor	Chen, I-Hsun	-	-
Jian-Ho Electronics (Jianli) Co., Ltd.	Legal Representative	Lo, Jung-Tsang	9,048	100 (Contribution ratio)
	Supervisor	Yuan, Chun-Hua		

Note: The liquidation the Volex JEM was completed on October 1, 2025.

(6) Overview of Affiliate Operations :

December 31, 2025; Unit: NT\$ thousand

Company Name	Paid-in capital	Total Assets	Total liabilities	Net value	Operating Revenue	Business Benefits	Profit or loss for the period (after tax)	Earnings per share (NT\$) (after tax)
Conquest International Holding Corporation	323,663	341,429	69	341,360	0	(1)	(46,289)	(4.57)
Evergrand Holdings Limited	90,630	281,216	0	281,216	0	0	(39,346)	(13.12)
Samoa Brighton Goal Limited	94,170	281,216	0	281,261	0	(1)	(36,346)	(13.12)
Joinsoon Electronics Manufacturing (Thailand) Co., Ltd	975,941	1,875,298	855,410	1,019,888	1,301,378	17,771	30,036	2.77
Dongguan Jian-Wei Electronics Products Co.,Ltd.	431,664	857,524	389,524	467,476	984,554	(56,969)	(61,994)	Note 1
Dongguan Jian-Yi Electronics Co., Ltd.	29,520	34,525	39,071	(4,546)	16,518	(193)	(553)	Note 1
Suzhou Jian Ho Precision Electronics Co., Ltd.	94,170	389,964	109,054	280,910	458,728	(9,351)	(39,332)	Note 1
Volex-Jem Co., Ltd. (Note)	0	0	0	0	0	(4)	(4)	-
Jian-Ho Electronics (Jianli) Co., Ltd.	9,048	87,347	87,034	313	208,382	(9,405)	(10,321)	Note 1

Note 1: For limited company type, this field is not applicable.

Note 2: The liquidation Volex JEM was completed on October 1, 2025.

(7) Consolidated Statements of Operations and Consolidated Financial Statements of Affiliated Companies

In accordance with the "Regulations Governing the Preparation of Consolidated Financial Statements of Affiliated Companies and Related Party Reports", the companies that should be included in the consolidated financial statements of affiliated companies for the year 2025 are the same as the companies that should be included in the consolidated financial statements of parent and subsidiary under IAS 27. The information required to be disclosed in the consolidated financial statements of related companies has already been disclosed in the consolidated financial statements of the former parent and subsidiary, and therefore, no separate consolidated financial statements of related companies will be prepared.

(8) Affiliate Report: Not applicable.

2.Private placement of marketable securities for the most recent year and up to the publication date of the annual report: None.

3.Holding or disposal of the Company's shares by subsidiaries in the most recent year and as of the publication date of the annual report: None.

4.Other necessary supplementary information: None :

IX. If any of the events specified in Article 36(3)(2) of the Securities and Exchange Act that have a significant effect on shareholders' equity or the price of securities have occurred during the most recent year and up to the date of publication of the annual report: None.

JOINSOON ELECTRONICS MFG. CO., LTD

Chairman : Huang, Chin-Hsiung